

Eclipse™ Snaplock
Architectural Panels System

INSTALLATION GUIDE

Non-Cyclonic

Eclipse™

Panel Installation

Important Note:

No1 Architectural Panels recommends you refer to the most recent release of this manual, as changes might be made for improvement purposes. If you're unsure which version of the manual you have, please contact No1 Architectural Panel Systems for assistance.

This manual should be read in conjunction with related Australian Standards, and all installation works must be carried out in accordance with the National Construction Code of Australia and the following standards:

- AS 1562.1 – design and installation of sheet roof and wall cladding
- SA HB 39:2015 – installation code for metal roof and wall cladding
- AS 2180 – metal rainwater goods – selection and installation
- AS 2179.1 - specification of rainwater goods, accessories, and fasteners metal shape or sheet rainwater goods, and metal accessories and fasteners
- AS 3500.3 – plumbing and drainage stormwater drainage

The installer is fully responsible for the proper interpretation of this manual, and in the eventual need for the adaptation of details provided on this manual to fulfill on site requirements the installer must achieve compliance with above mentioned standards. No1 Architectural Panels Systems is not to be held responsible for any work carried out outside of the recommendations provided on this manual and/or NCC & Australian Standards. For assistance, please contact the No1 APS team.

Technical Specifications

Rib Height	25mm or 38mm
Standard Pan widths	320mm and 520mm (25mm ribs) 285mm and 485mm (38mm ribs)
Minimum sheet length	750mm
Maximum recommended sheet length	8000mm*
Custom pan widths	Available. Please consult with our APS team (May require additional design parameters)

Tested and certified to comply with AS 1562.1:2018
Design and Installation of Sheet Roof and Wall Cladding - Metal. It replaces AS 1562.1-1992

Concealed fixed.

*Considering the characteristics of Eclipse™ as a clip based fixed architectural panel. Typically shorter panels will look flatter, whilst increased lengths may exhibit increased vulnerability to the manifestation of oil canning.

For projects requiring longer panels contact our No1 Architectural Panel Systems team.

For additional design parameters or project specific technical data, please contact the No1 Architectural Panel Systems team.

General

- A. Provide components required for a complete metal roof panel assembly including trim, capping, fascia, corner, Z closures, flashings, sealants, gaskets, fillers and similar items. Match material and finish of metal roof panels, unless otherwise indicated.
- Flashing: Provide flashing at eaves, valleys, sidewalls, headwalls, rakes, transitions, hips and ridges fabricated of same metal as metal roof panels.
- B. General: Provide metal roof panels of full length from eave to ridge. Anchor metal roof panels and other components of the work securely in place, with provisions for thermal and structural movement.
- Field cutting of metal roof panels by torch, plasma cutter or saw blade is not permitted.
 - Mechanically fasten ridge end of metal roof panels and allow eave end free movement due to thermal expansion and contraction.
 - Provide metal Z closures at high-side eave, rake edges, rake walls, each side of ridge and hip caps and any other area indicated in the manufacturer's installation details.
 - Lap metal flashing over metal roof panels to allow moisture to run over and off the material.
- C. Fasteners:
- Panel fixing: it is recommended to use minimum Class 3, 25mm flat top/wafer head fastener.
- D. Metal protection: Where dissimilar metals will contact each other or corrosive substrates, protect against galvanic reaction by painting contact surfaces with bituminous coating, by applying rubberised-asphalt underlayment to each contact surface, or by other permanent separation as recommended by metal roof panel manufacturer. Please use a suitable fastener.

Whilst this will work for the majority of metals, there are instances where incompatibility with coatings/ underlayments can also occur- for example, Zinc (as in titanium zinc) and bitumen are incompatible. If you are unsure, please contact Nol Architectural Panel Systems.

Field- assembled Eclipse™ panel installation

- A. Metal roof panels: Fasten metal roof panels to a solid substrate with concealed clips the manufacturer's engineering report or engineer recommendation based on project location and wind load requirements.
- Clip Spacing: Maximum 600mm centres for both internal and external span. For specific wind load requirements, please consult with our team.
 - Install clips to under side (male edge) of panel with two minimum class 3 - 25mm wafer head fasteners.
 - Push female edge over clip and male edge for a snap tight seam.
- B. Metal soffit panel: Provide metal soffit panels that are the full width of the soffits. Install panels perpendicular to support framing.
- Flash and seal panels with weather closures where metal soffit panels meet walls and at the perimeter of all openings.
- C. Installation on plywood requires the following:
- Continuous air gap (20mm for wall, 40mm for roofing) must be incorporated unobstructedly beneath the plywood substrate for ventilation.
 - Breathable waterproofing membrane fixed to outer/external side of plywood substrate.
 - Eclipse™ roofing is installed on a minimum 18mm plywood (15mm for wall cladding) substrate. (For projects in BAL areas, please consult our team for alternative / appropriate substrate options)
 - Concealed fasteners attached directly into plywood substrate.
 - Push and click seams together (female rib of panel over the fastened male rib) for a snap tight seam.

Delivery, storage, and handling

For the installer to work safely, it is recommended that you wear protective gloves whilst handling metal panels and flashings to avoid personal harm and marks on material (i.e. marks caused by sunscreen). Be aware metal panels have sharp edges and should be treated carefully. Whilst holding a panel, assure even support throughout the length of it (i.e. hold it with arms open, to avoid creating uneven pressure on panels and flashings), and seek help when carrying longer pieces to lower risk of creasing and scratches.

Always inspect delivered items thoroughly to ensure there are no missing items and all goods are in good condition prior to starting installation. When laying metal sheets and flashings on ground, allow the sheet to naturally hang towards the ground with even support and avoid laying goods on hard/rough surfaces that could potentially scratch or damage them.

Goods should be stored in a safe area, off the ground high enough to allow for air circulation underneath and to prevent rising water from contacting products.

If covered, allow for air circulation between draped edges of tarpaulin and slightly elevated on one side as to allow for proper drainage until ready for installation. Prolonged storage is not recommended.

Note: Avoid walking on Eclipse™ panels when they are placed on the ground or resting on uneven surfaces. Doing so may cause permanent crease marks, compromising the visual quality and overall aesthetics of the panels.

Safety on site

Carrying long and heavy panels can be a challenging exercise on a busy job site. Always be aware of safety laws and comply with safe working conditions imposed by each site. Be aware of others whilst carrying panels throughout a site and avoid resting panels in vertical position in case wind could blow them down. Always be extra careful and consider postponing installation in case of adverse weather and windy conditions.

Cleaning and protection

- A. Unless otherwise indicated in manufacturer's written installation instructions, remove temporary protective coverings and strippable films if applicable as metal roof panels are installed. On completion of metal roof panel installation, clean finished surfaces as recommended by metal roof panel manufacturer. Maintain in a clean condition during construction.
- B. To prevent rust staining, remove any fillings caused by dilling or cutting immediately from finished surfaces.

Oil canning

Whilst usually undesirable, oil canning is a common natural occurrence to all metals and results from the natural movement of the panel caused by its expansion and contraction once exposed to temperature variation.

Nol Architectural Panel Systems takes all possible measures to manufacture panels with maximum quality control resulting in an aesthetically flat looking panel, and for this reason oil canning on installed panels will not be considered a cause for panel rejection.

Please speak to Nol for assistance on how to mitigate oil canning on your installation.



Eclipse™ Panel

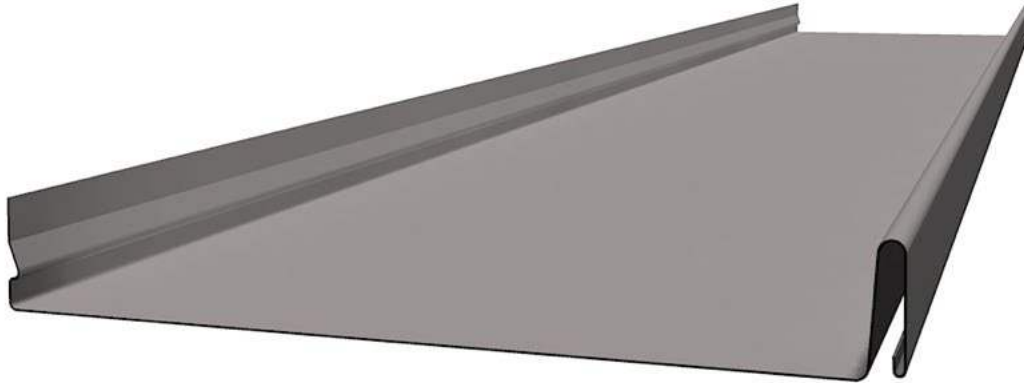

Options	Rib Height (A)	Pan Cover (B)	Requires Plywood Substrate*
25 x 320	25mm	320mm	No
25 x 520	25mm	520mm	Yes
38 x 285	38mm	285mm	No
38 x 485	38mm	485mm	Yes

*Plywood substrate is always recommended for increasing serviceability, and reducing oil canning.

Eclipse™ Clip

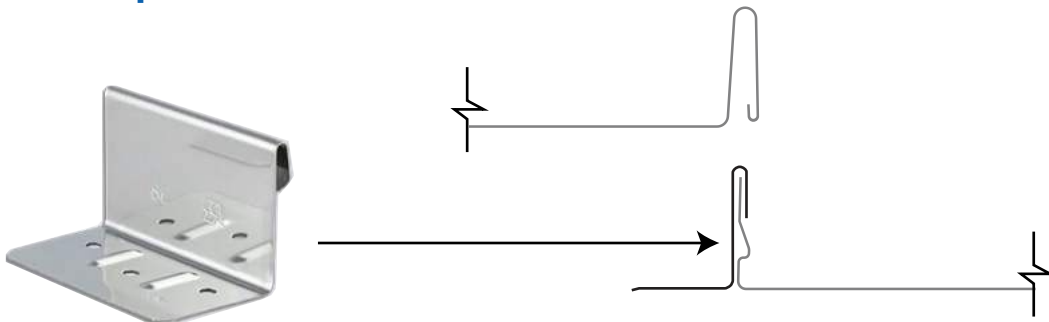

Index

Installation Overview	2
Panel Profile Information	5
Fixing Specification	7
Panel Stop End Details	9
Panel Preparation - Closing Ribs	10
Cladding Roof to Wall Details on Mansard	13
Hooking Clip & Z-Closure Flashing	14
Roof Cladding Flashing Details on Plywood	18
Wall Cladding Flashing Details on Plywood	26
Roof Cladding Flashing Details on Steel Batten	31
Wall Cladding Flashing Details on Steel Batten	39

Eclipse™ Fixing Specification

Fixing Specification

Each Eclipse™ clip must be fixed with 2 fasteners as per below

G550 Steel Battens (Minimum 0.55mm BMT)

10g-16 x 16 wafer screws OR M5.4 - 13 x 28mm Ultra Low APS

70x35 Timber

10g x 25 bugle screws OR M5.4 - 13 x 28mm Ultra Low APS

18mm Plywood (Roof application)

10g x 25 bugle screws OR M5.4 - 13 x 28mm Ultra Low APS

15mm Plywood (Wall cladding application)

10g x 25 bugle screws OR M5.4 - 13 x 28mm Ultra Low APS

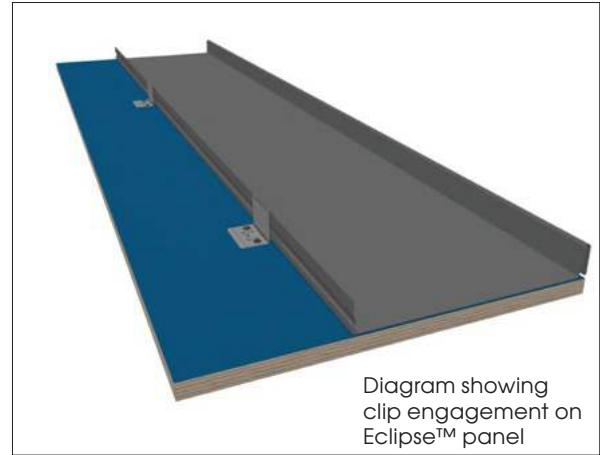

Eclipse™ Maximum Recommended Spacing of Fasteners

Normal conditions

Roof & wall

Material	End Span	Internal Span
Steel 0.55BMT G300	600mm	600mm
Corten Steel 0.55BMT G300	600mm	600mm
Aluminium 0.7 / 0.8BMT 5005 H34	600mm	600mm

Substrate Options for Eclipse™ Snaplock Panel Installation

Eclipse™ Snaplock panels can be installed over both continuous substrates (such as plywood) and batten systems, for roofing and wall cladding applications.

However, a continuous substrate is strongly recommended for optimal system performance. Key benefits of using plywood include:

- **Improved insulation:** Enhances both thermal and acoustic performance.
- **Better aesthetics:** Consistent support provides even backing along the full panel length, which helps minimise oil canning and crease marks.
- **Trafficability:** Allows safe access for maintenance without damaging the Eclipse™ panels.
- **Increased waterproofing:** Acts as a secondary layer of weather protection beneath the Eclipse™ panels.
- **Passive ventilation:** When ventilated at the back, plywood supports passive ventilation principles, helping to reduce building heat gain and improve drainage in roof and wall systems. Proper ventilation also mitigates condensation-related issues.

Installation over battens is possible, but may not be suitable in the following scenarios:

- **Flatness is critical:** Battens and Eclipse™ panels expand and contract in different directions, increasing the likelihood of oil canning.
- **Roof access is required:** While it is technically possible to walk on Eclipse™ panels installed over battens, doing so may result in permanent damage such as crease marks. If access is unavoidable, temporary platforms must be used to distribute weight and prevent direct pressure on the panels.
- **Batten alignment is inconsistent:** Misaligned battens can exert uneven upward pressure on the Eclipse™ panels, leading to aesthetic issues such as oil canning or creasing.

Important Notice:

No.1 Roofing & Building Supplies will not be held liable for any aesthetic imperfections, including oil canning or crease marks, resulting from installation over battens.

Fixing to Plywood Detail

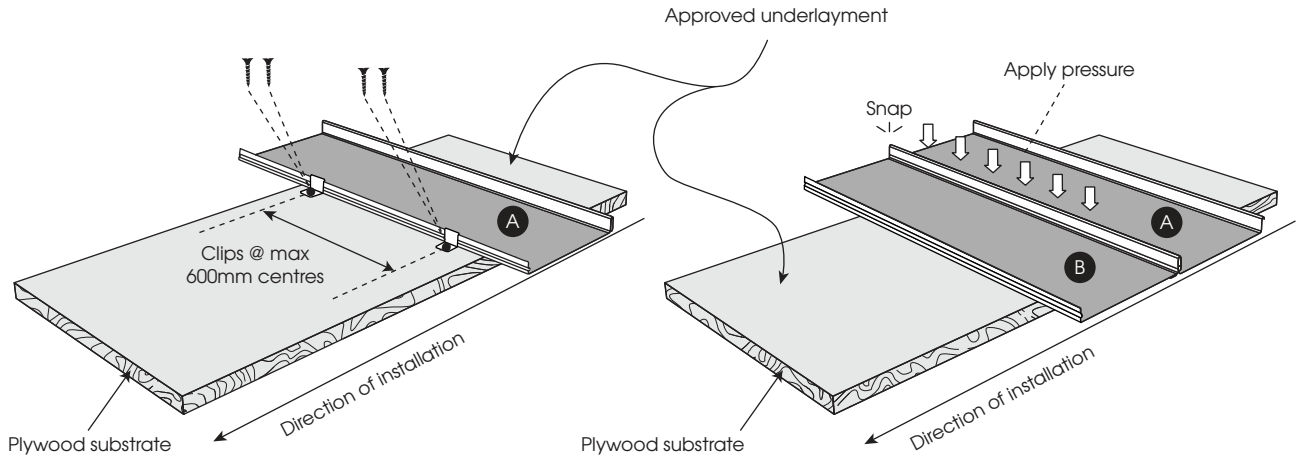

1 Position Eclipse™ clips over the male edge of panel, at maximum 600mm centres apart and fix it down to the battens with 2 x architectural low profile screws*.

2 Secure following panel B by positioning female edge of Eclipse™ panel over male edge of previously fixed panel A and applying pressure until it "Snaps" in place.

Repeat steps as required.

Fixing to Steel Batten Detail

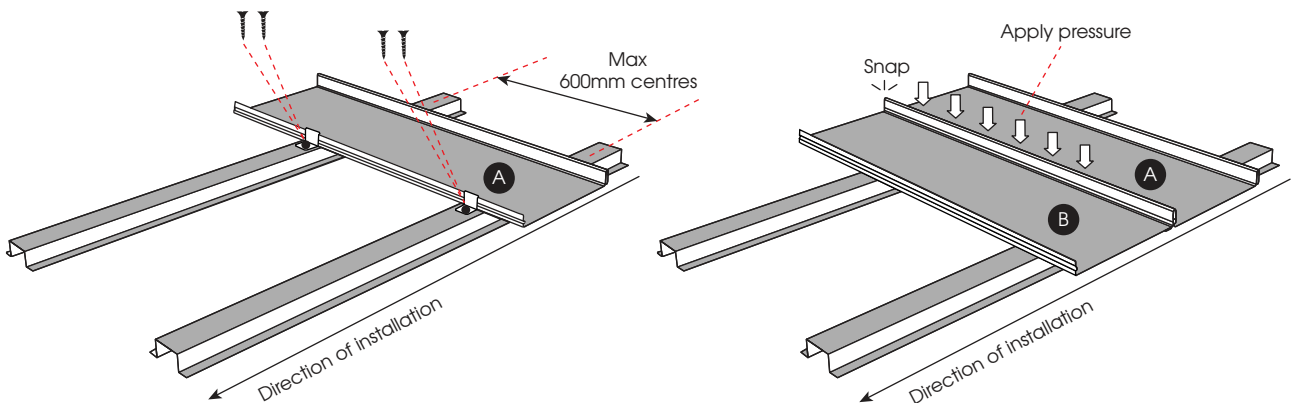

1 Position Eclipse™ clips over the male edge of panel and fix it down to the battens with 2 x architectural low profile screws*.

2 Secure following panel B by positioning female edge of Eclipse™ panel over male edge of previously fixed panel A and applying pressure until it "Snaps" in place.

Repeat steps as required.

Important: Avoid stepping over clips

Eclipse™ Snaplock panels are secured to the substrate (battens or plywood / continuous substrate) using clips. Each clip requires two screws for proper installation. Avoid stepping on installed panels whenever possible. If stepping on panels is unavoidable, do not step directly over the clips or ribs. This helps prevent localised pressure that can cause panel bruising or surface damage.



*The use of non recommended screws might affect the aesthetics of Eclipse™ panels. Please consult with our APS team for your best option.

Panel Upper End Preparation - Stop End Option

- 1 Mark upper end of panel with line parallel to upper edge.

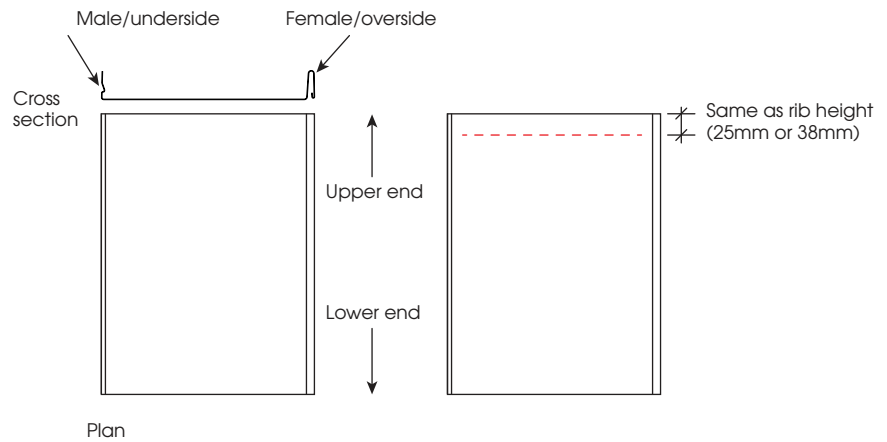

- 2 Insert a folding tool or flat head hand seamer/pliers on the upper end of the panel ensuring alignment with marked line.

Fold upper end up as close to 90° as possible, being careful not to pierce face of panel.

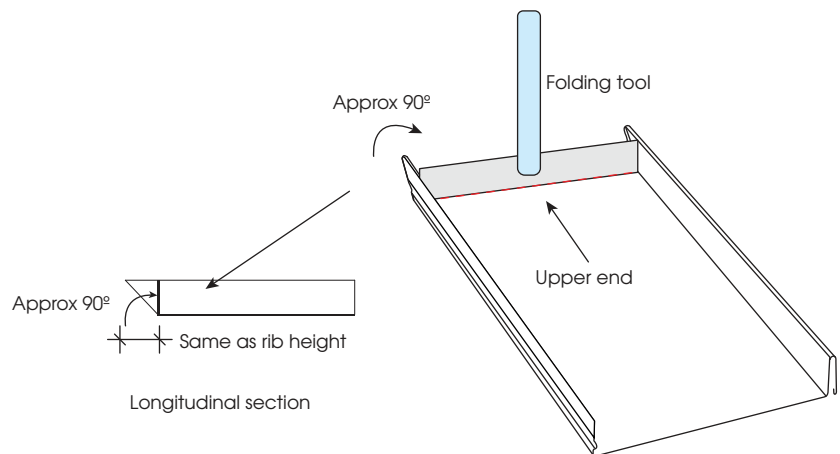

- 3 Use a rubber mallet to straighten stop end (folded end)*.

Rubber mallet

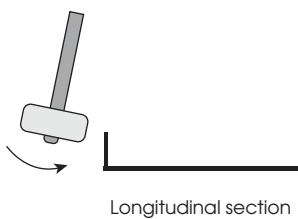

*Additional tools might be required for better preparation of Eclipse™ panels. Please consult with our APS team.

- 4 Mark female rib with an upright line perpendicular to the direction of the ribs. Using a metal snip, cut out rib following marked line.

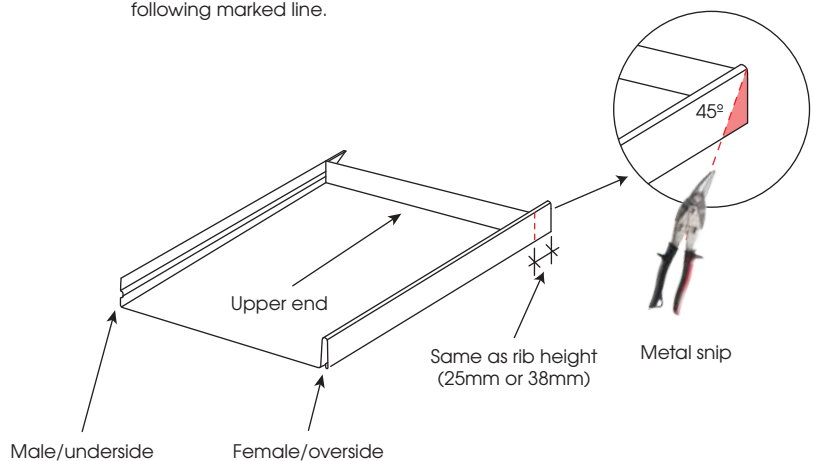

Eclipse™ Panel Preparation - Bottom Hook & Closing Ribs

- One of the steps to enhance the overall aesthetics of Eclipse™ Snaplock panels is to ensure there is adequate allowance for proper expansion and contraction. In some cases, this involves creating a “bottom hook” fold at the lower end of each panel, allowing it to hook onto the fascia starter flashing. This improves panel flatness and helps prevent water ingress at the lower roof point by blocking the gap between the panel and the substrate. It also helps to deter vermin ingress at that location.
- Eclipse™ Snaplock panels feature a slim rib profile, available in heights of 25 mm or 38 mm, and approximately 6 mm wide. In certain situations, it is advisable to “close” the rib ends to prevent vermin and ember ingress (particularly in BAL areas), or to enhance the overall appearance.

Both steps must be carried out on-site by the installer and requires specialised tools, such as hand seamers, flat pliers, snips, and folding tools

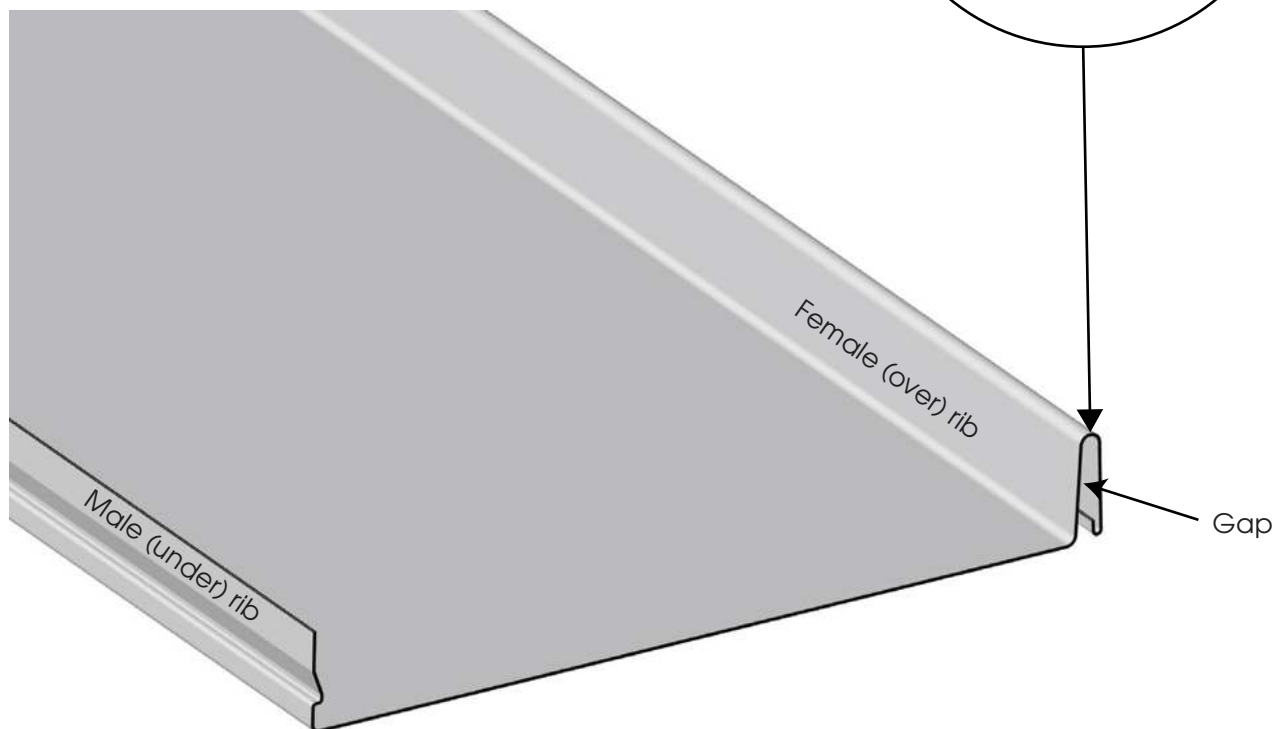
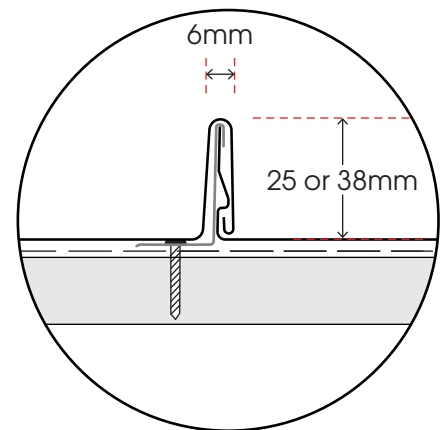

Eclipse™ Panel Preparation - Bottom Hook & Closing Ribs

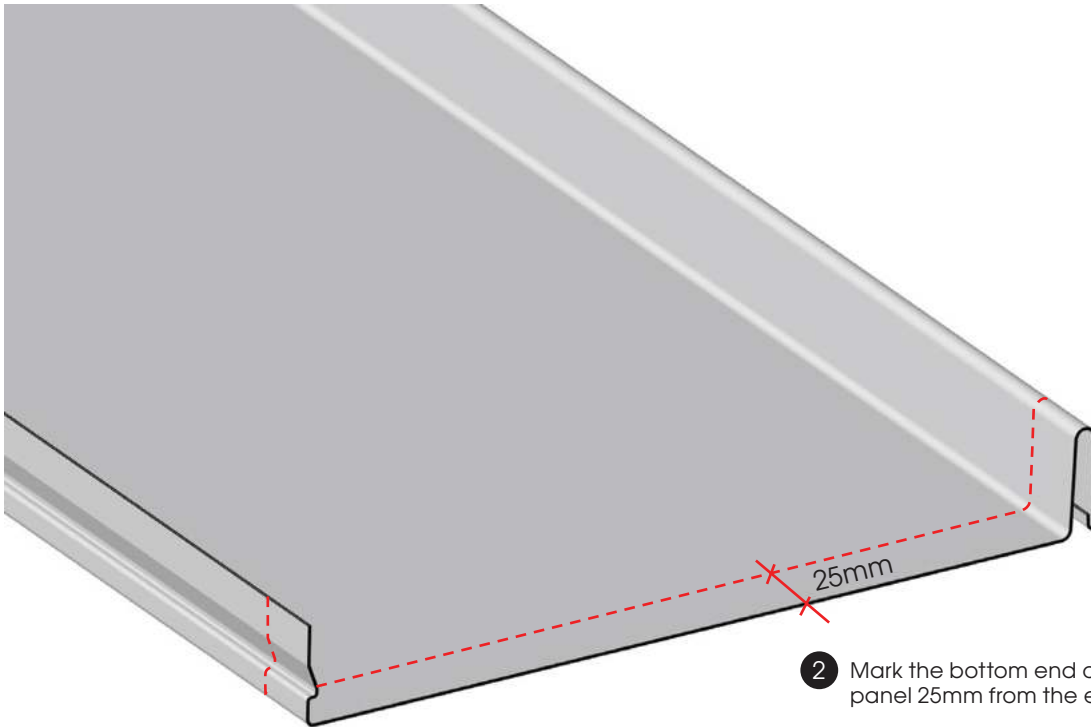

- 2 Mark the bottom end of the panel 25mm from the end.

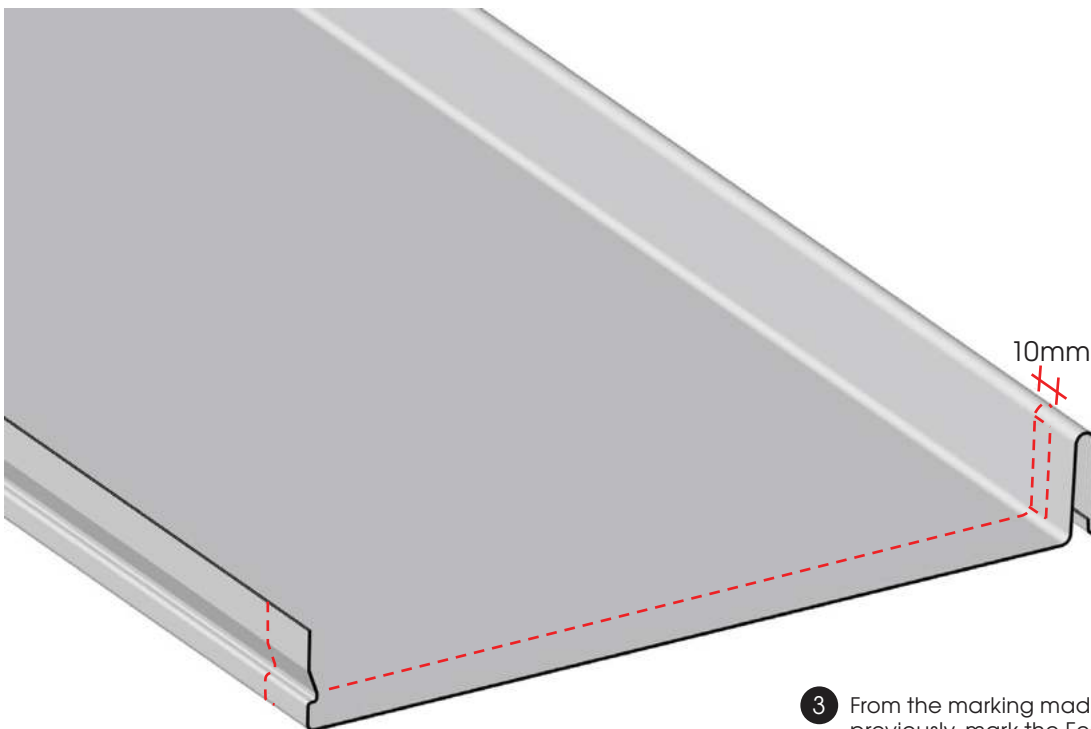

- 3 From the marking made previously, mark the Female (over) rib of Eclipse™ panel 10mm

Eclipse™ Panel Preparation - Bottom Hook & Closing Ribs

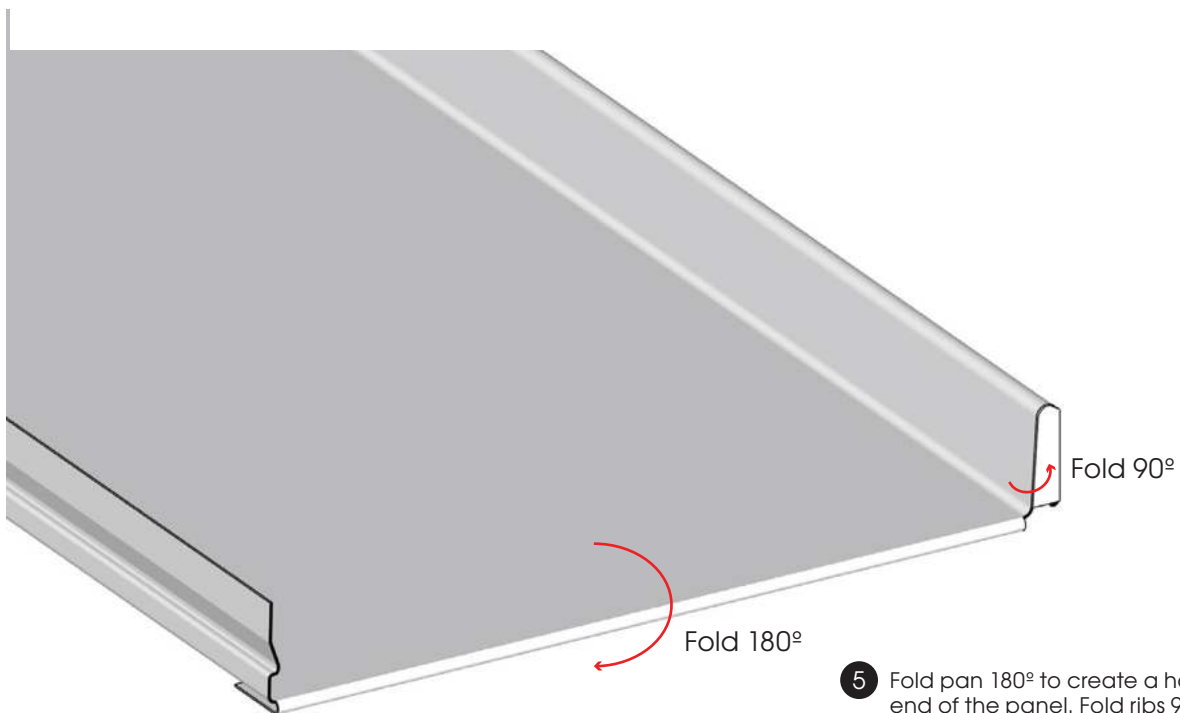
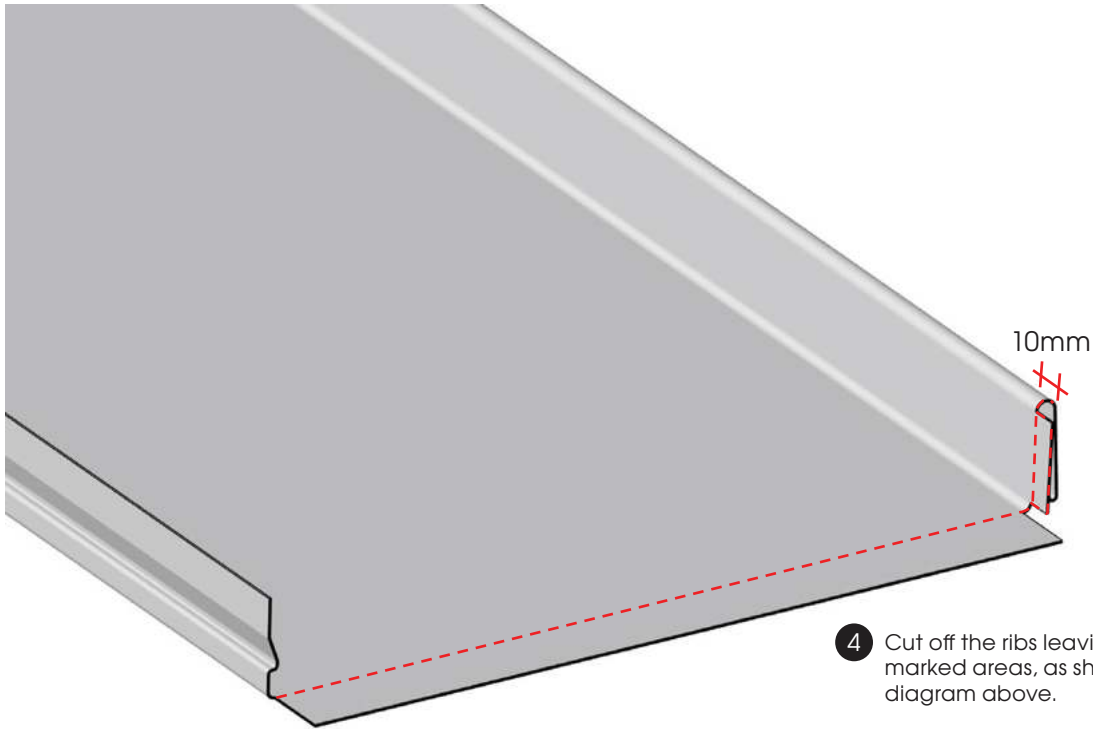

Eclipse™ Cladding Roof to Wall Detail (Mansard Detail)

This common architectural detail requires the wall sheet to be manufactured a minimum of 50mm longer than the wall height.

The top end of the wall sheet is notched and a minimum 50mm fold created to sit below the roof sheet.

The roof sheet is also notched at the bottom end to match the wall rib height, the ribs are cut back to the pans.

Use butyl tape and silicone to make the joint weathertight.

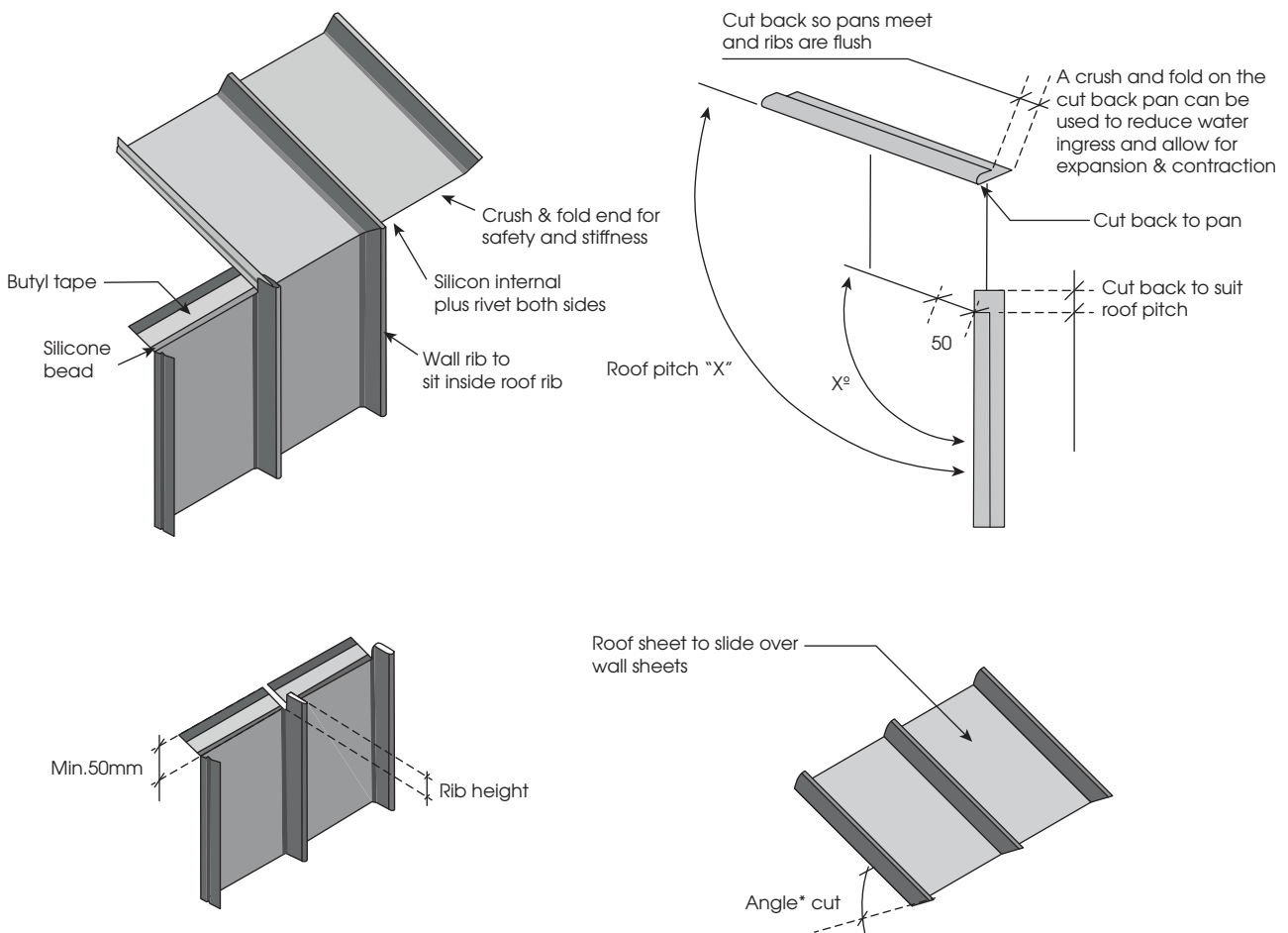

*Angle will differ depending on roof and wall pitch. If unsure, please consult with our APS team.



Ensure that the anti-capillary drain on the roof is allowed to drain before the roof/wall joint.

Hooking Clip & Z-Closure Flashing - Positive Restraint Required

Eclipse™ panels use a clip-fixing method, which allows for thermal expansion and contraction. Since the clips are fixed—not the panels—the panels can slide under the clips as their length changes with temperature.

To ensure proper function and prevent panels from sliding downward over time, positive restraint at the upper section is essential. This restraint does not relate to how the clips are fixed, but rather to guiding the panel's movement and securing its position.

Two acceptable methods for achieving this are:

- a. **Z-Closure at the upper section of the panel**
- b. **Hooking the clip into a designated section of the panel's underside edge**

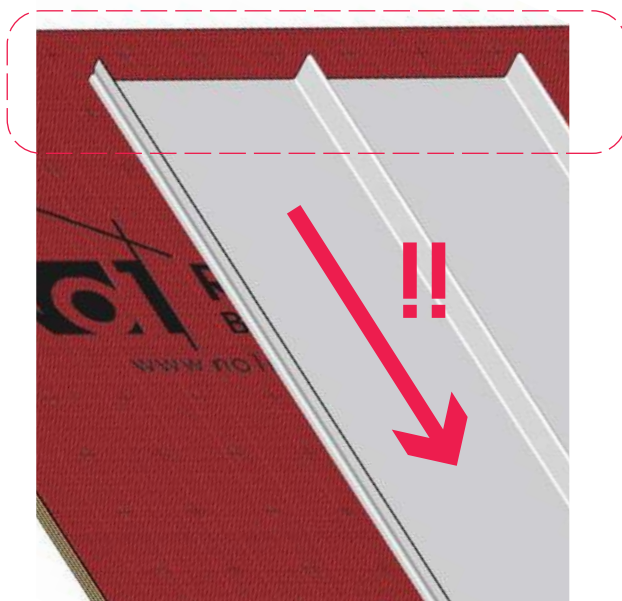

Important: Eclipse™ panels must be restrained at the upper section, during installation, as to avoid panels sliding down over time.

a. Z-Closure Positive Restraint Method

Using this option, an installer will need to incorporate a 'Z-Closure' flashing at the upper section of each Eclipse™ panel, as to create a water seal end, and allow for a ridge cap or parapet cap to be hooked onto the Z-Closure, as per below:

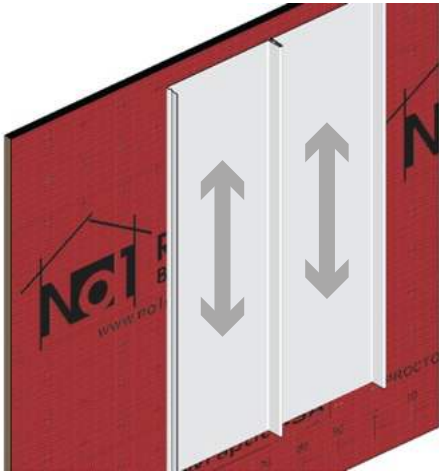

1 Panel Positioning

Place Eclipse™ panels in the desired location, ensuring the substrate is level and even.

An uneven substrate may cause visible creasing on the panels. Always inspect and correct the substrate before installation.

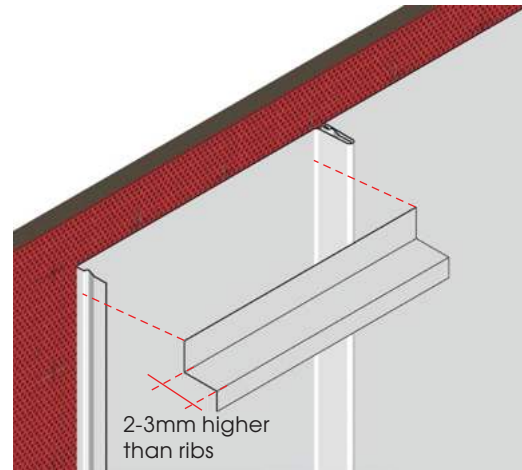

2 Z-Closure Flashing Preparation

Order Z-Closure flashings to suit the full width of the wall or roof. The vertical dimension of the Z-Closure must be slightly taller than the Eclipse™ panel rib height. Cut each Z-Closure to fit snugly between the panel ribs.

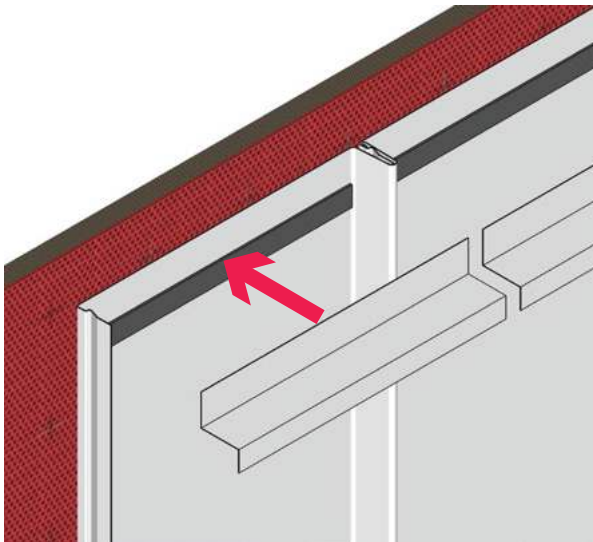

3 Butyl Tape Application

Apply butyl tape to the upper portion of the Z-Closure base (where it contacts the panel) to prevent downward ooze when fastened.

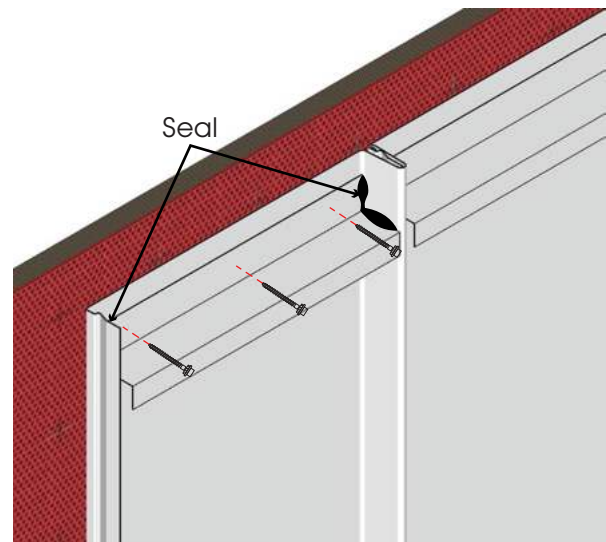

4 Fixing the Z-Closure

Position the Z-Closure over the panel and secure it using three hex head screws with washers per length. Apply approved sealant along the vertical leg of the Z-Closure where it meets the panel ribs to ensure a complete weatherproof seal.

b. Hooked Clip Method

This method involves cutting a notch into the underside edge of the Eclipse™ panel to allow the clip to hook into it. It offers a cleaner, more seamless appearance compared to the Z-Closure method.

Important:

This method is not recommended for wall cladding applications where panel lengths exceed 3 metres or in areas exposed to strong winds - for these cases we recommend the Z-Closure method.

Unlike the Z-Closure method, hooked clips do not provide a watertight seal at the top edge of the panel. Therefore, a stop end must be incorporated to the upper end of the panel to prevent water ingress and ensure waterproofing.

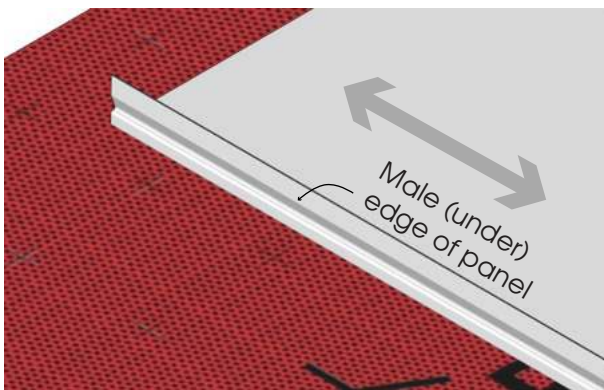

1 Panel Positioning

Place Eclipse™ panels in the desired location, ensuring the substrate is level and even.

An uneven substrate may cause visible creasing on the panels. Always inspect and correct the substrate before installation.

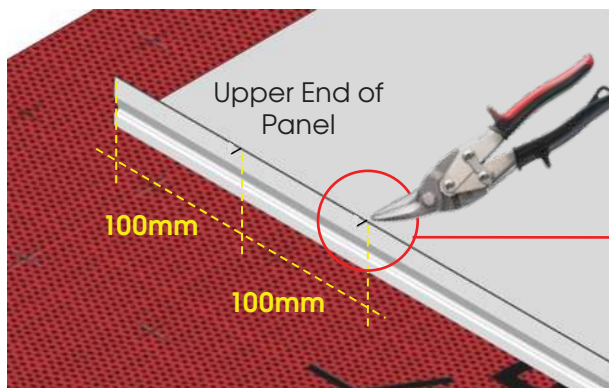

2 From the upper end of the panel, over the male (under) edge, mark 100mm and 200mm.

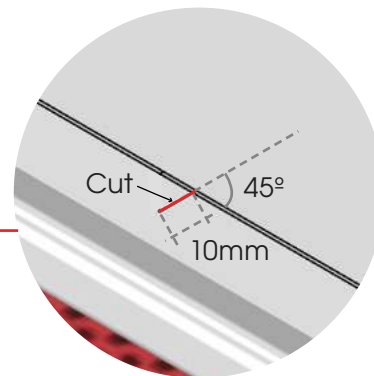

3 Cut a 10mm cut in 45 degrees angle on both marks.

b. Hooked Clip Method - continuation

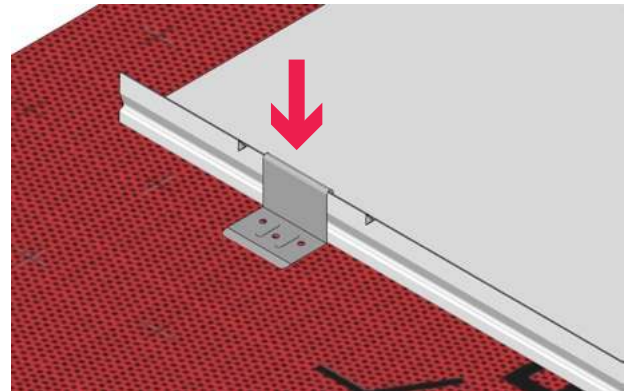
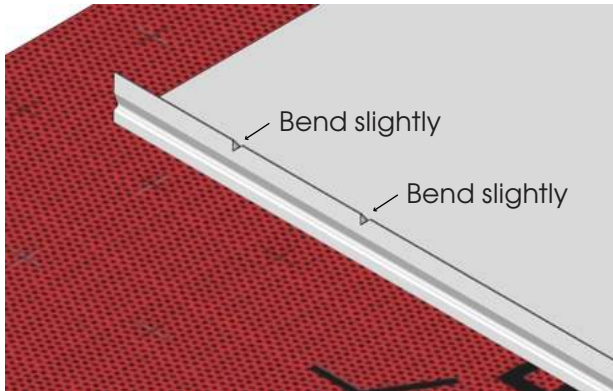

- 4 Using pliers, carefully bend the pre-cut section of the panel's underside approximately 2mm sideways—just enough to allow the clip to fit securely between the bent tab and the male edge of the Eclipse™ panel.

Do not over-bend. If the tab is bent too far, gently adjust it back toward the male edge using pliers to ensure a snug fit.

- 5 Place first clip, between cut tabs, ensuring it is correctly placed over the Eclipse™ panel male (under) edge.

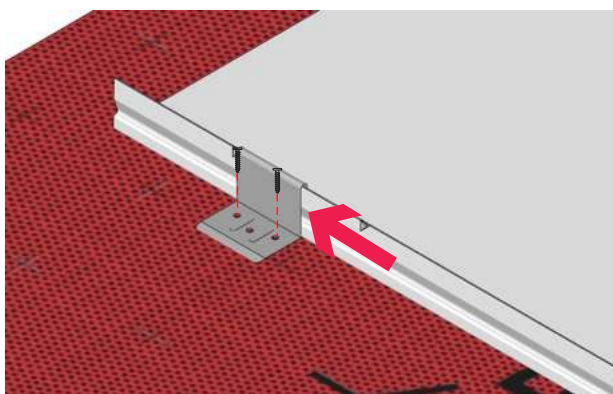

- 6 Slide the clip upward until it is securely positioned in the gap between the bent tab and the male edge of the Eclipse™ panel.

Fix the clip using a minimum of two recommended fasteners.

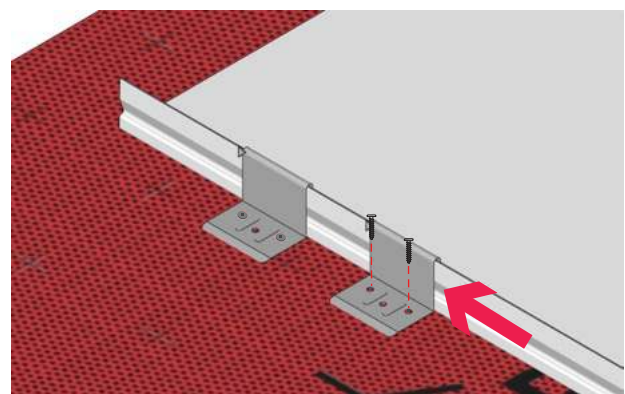

- 7 Repeat the previous steps to install the second clip.

Once two clips are securely hooked into the panel, the Eclipse™ panel is positively restrained.

From this point onward, continue with standard clip fixing (non-hooked) at a maximum of 600mm centres.

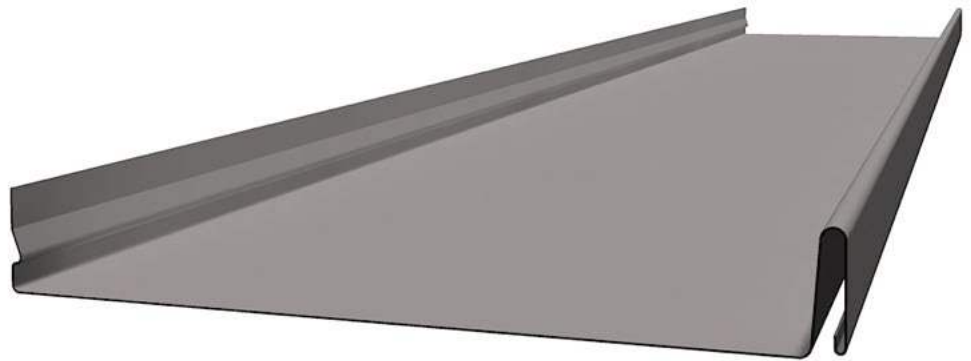

Eclipse™ Roof Cladding Flashing Details on Plywood

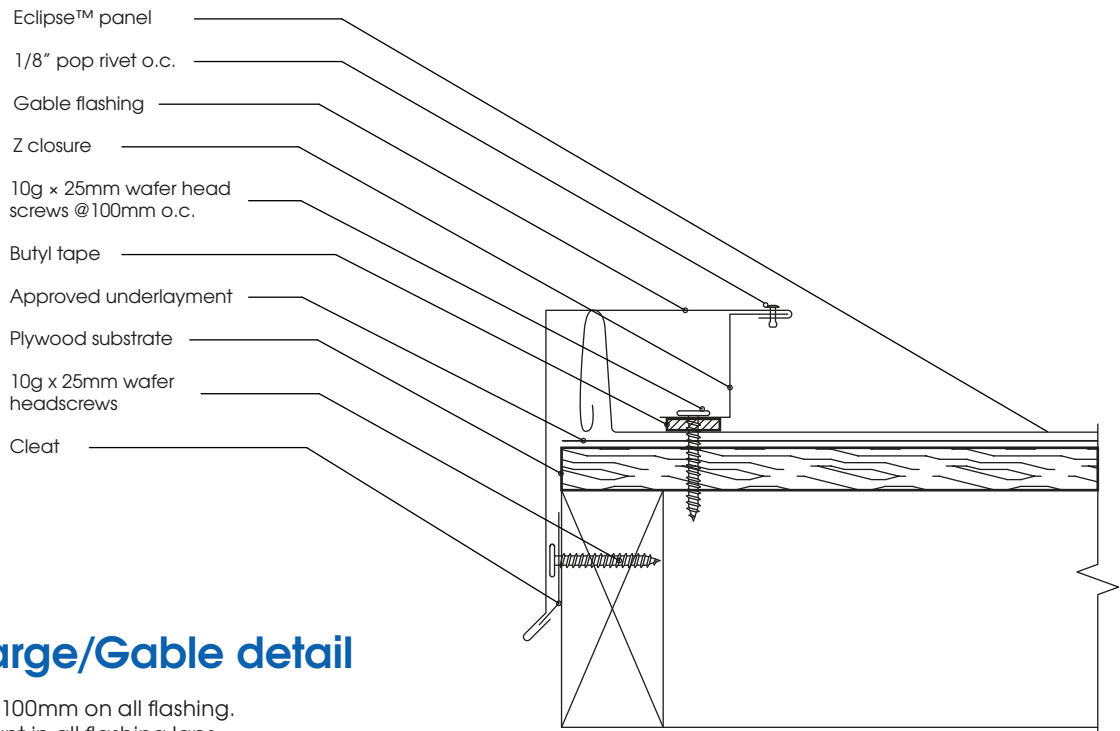

BG1 - Barge/Gable detail

Note: Minimum 100mm on all flashing.
Approved sealant in all flashing laps.

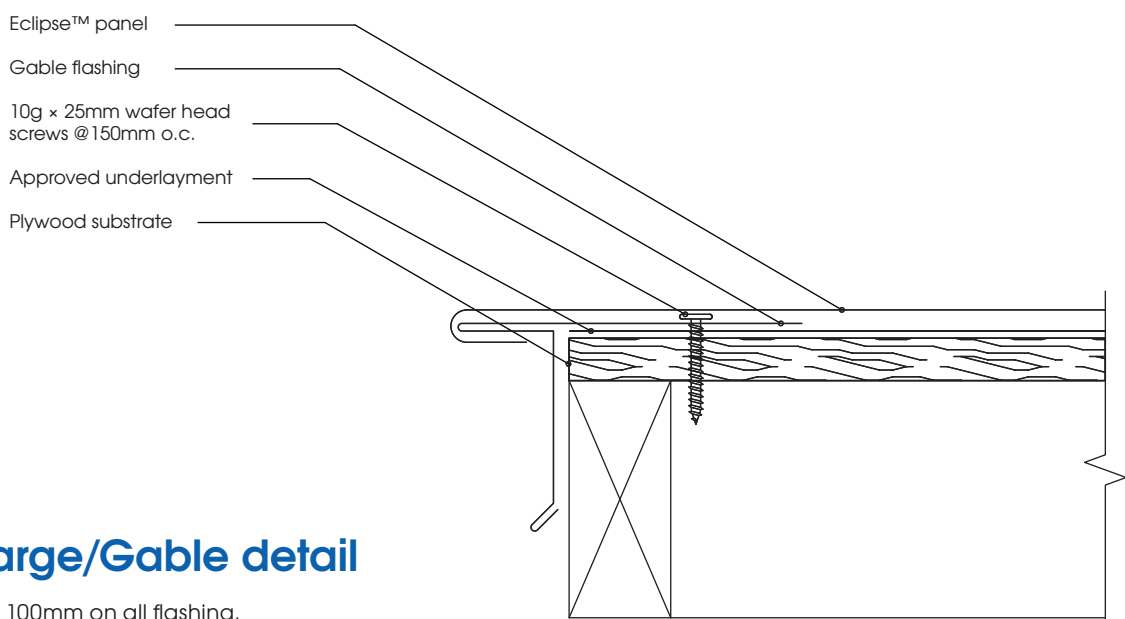

BG1 - Barge/Gable detail

Note: Minimum 100mm on all flashing.
Approved sealant in all flashing laps.

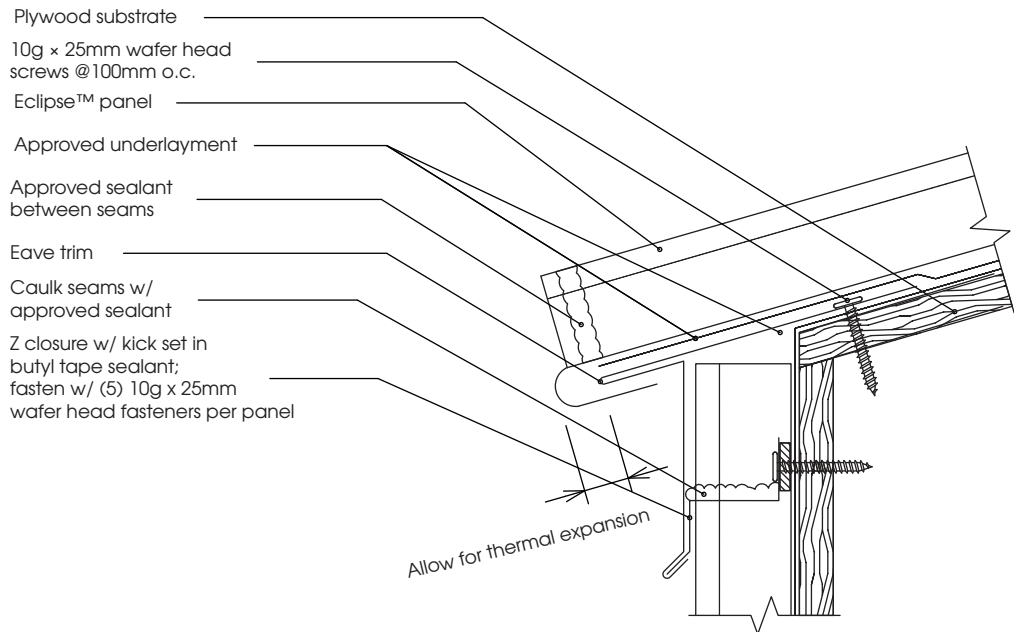

T1 - Roof/fascia transition detail

Note: Minimum 100mm lap on all flashing.
Approved sealant in all flashing laps.

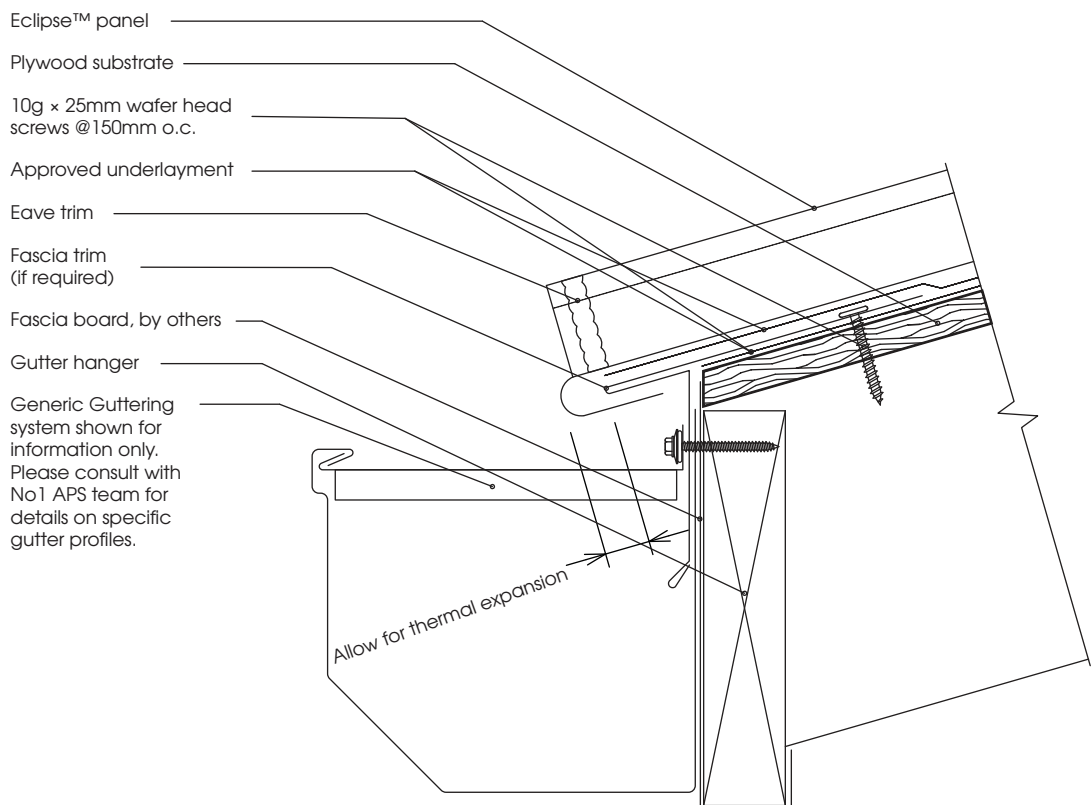

EG1 - Eave w/gutter detail

Note: Minimum 100mm lap on all flashing.
Approved sealant in all flashing laps.

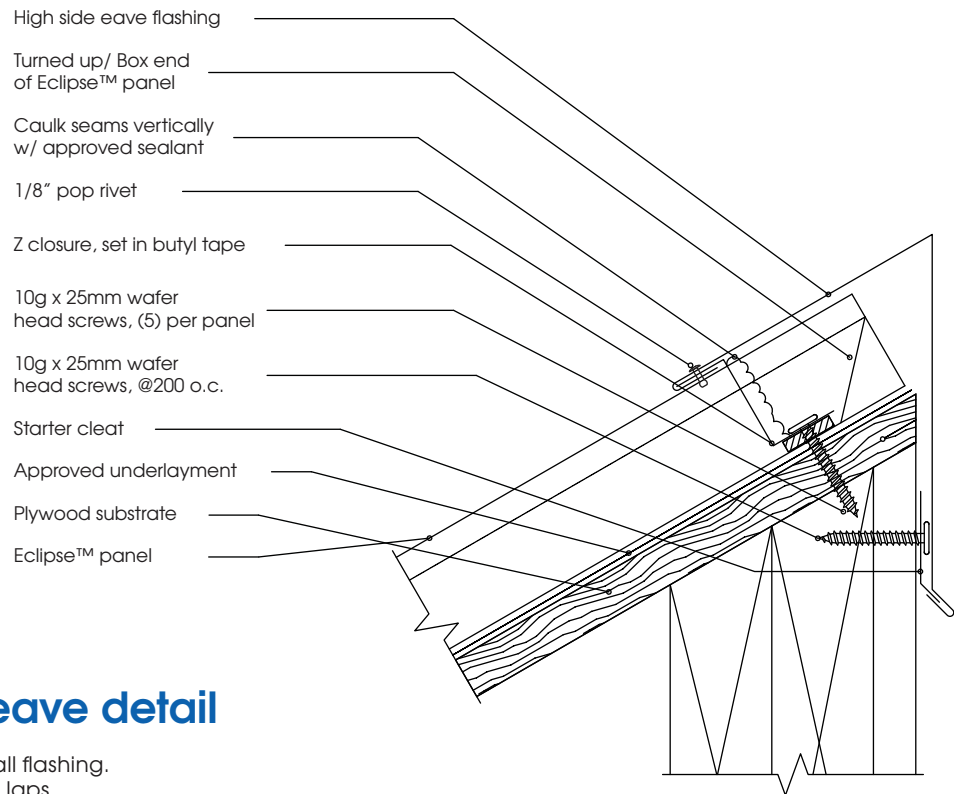

PK1 - High side eave detail

Note: Minimum 100mm lap on all flashing.
Approved sealant in all flashing laps.

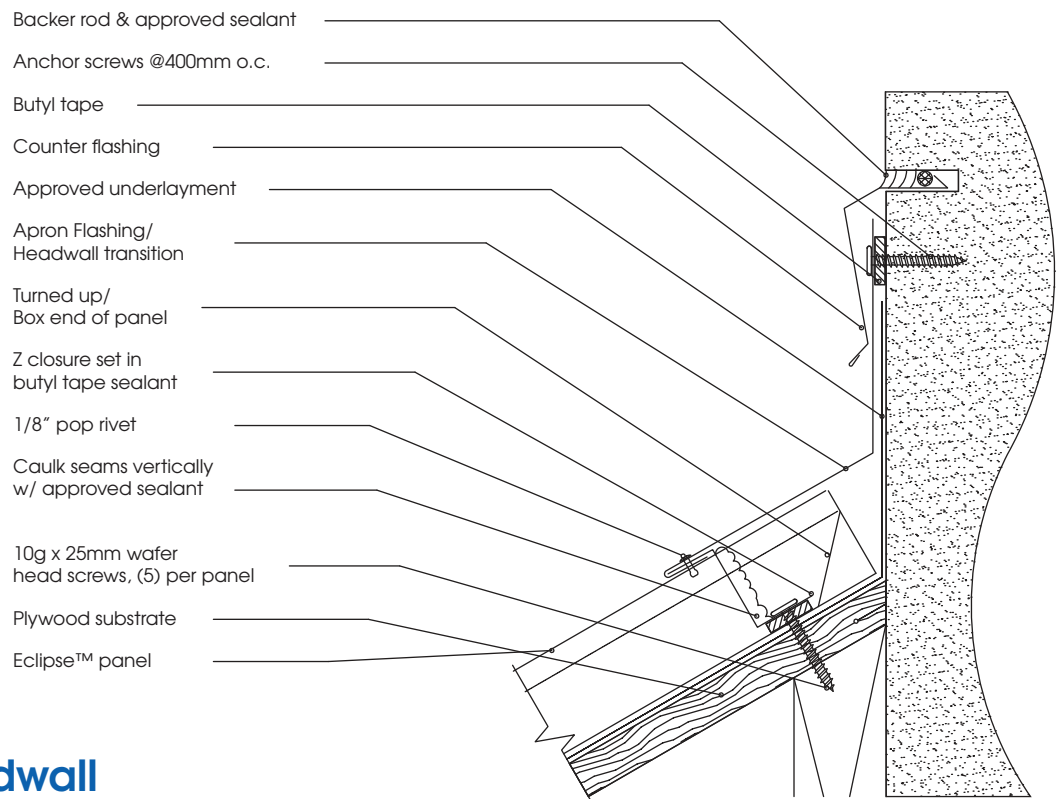

HW1 - Headwall Apron Flashing detail

Note: Minimum 100mm lap on all flashing.
Approved sealant in all flashing laps.
Turn approved underlayment 75mm vertically minimum.

- Anchor screws @600mm o.c.
- Siding, by others
- Anchor screws @400mm o.c.
- Butyl tape
- Counter flashing
- Approved underlayment
- Apron Flashing/ Headwall transition
- Folded Up/ Box end of panel
- Z closure set in butyl tape
- 1/8" pop rivet
- Caulk seams vertically w/ approved sealant
- 10g x 25mm wafer head screws, (5) per panel
- Plywood substrate
- Eclipse™ panel

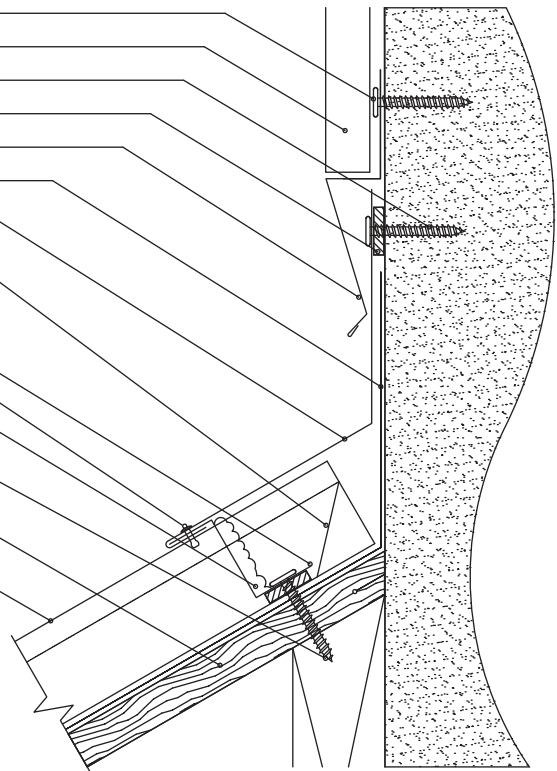

HW2 - Headwall/ Apron Flashing detail

Note: Minimum 100mm lap on all flashing.
Approved sealant in all flashing laps.
Turn approved underlayment 75mm vertically minimum.

- Approved sealant
- Fastener @600mm o.c.
- Butyl tape
- Anchor screws @400mm o.c.
- Butyl tape
- Surface mount counter flashing
- Approved underlayment
- Apron Flashing/ Headwall transition
- Folded Up/Box end of panel
- Z closure set in butyl tape sealant
- 1/8" pop rivet
- Caulk seams vertically w/ approved sealant
- 10g x 25mm wafer head screws, (5) per panel
- Plywood substrate
- Eclipse™ panel

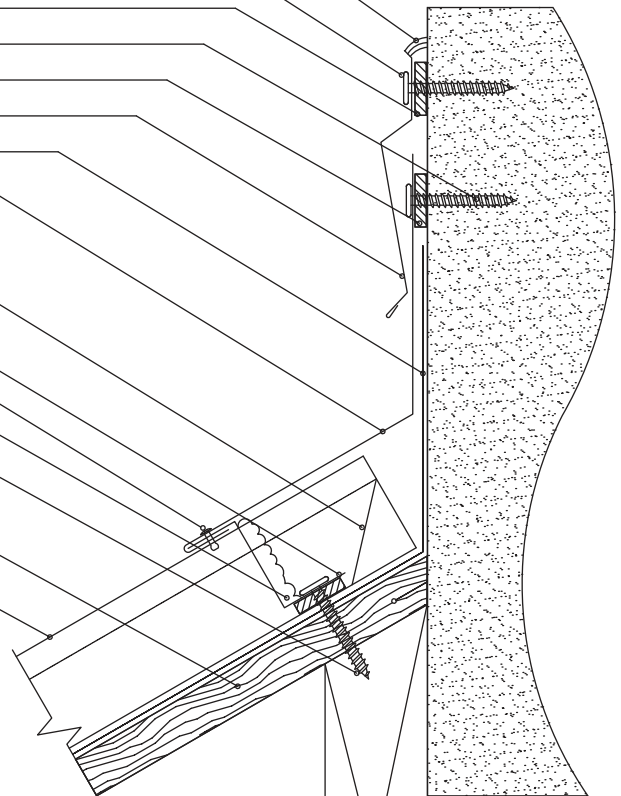

HW3 - Headwall Apron Flashing detail

Note: Minimum 100mm lap on all flashing.
Approved sealant in all flashing laps.
Turn approved underlayment 75mm vertically minimum.

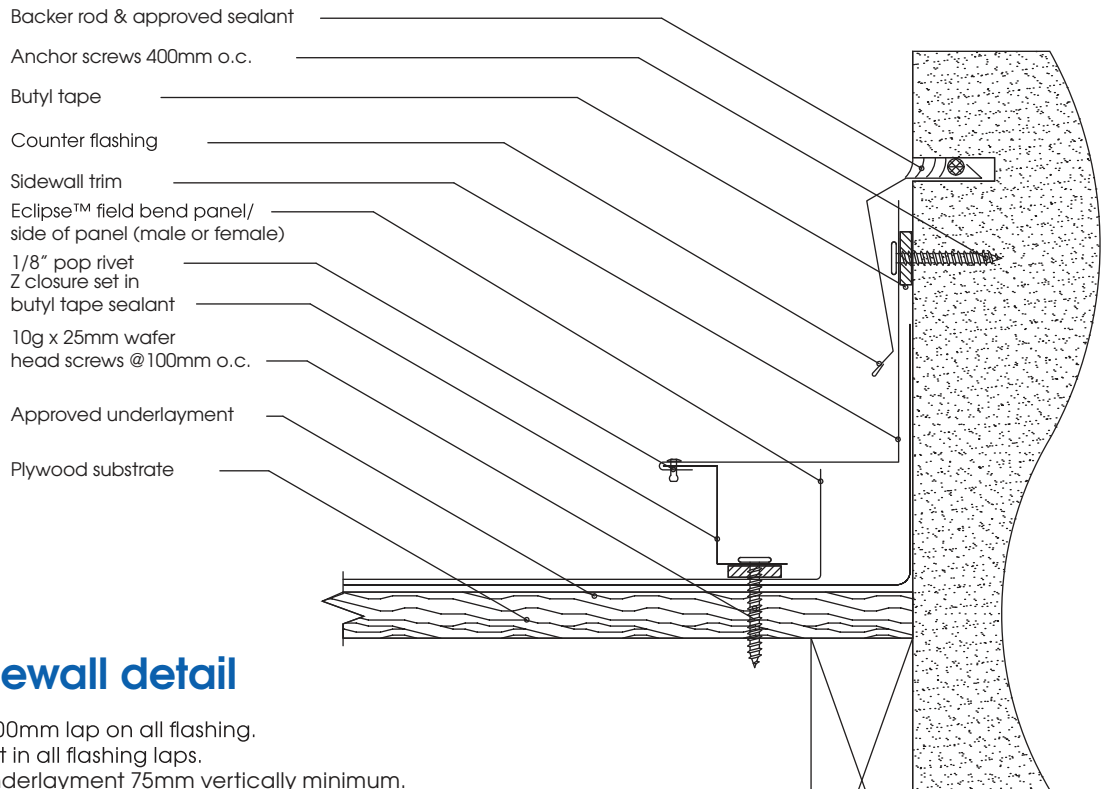

SW1 - Sidewall detail

Note: Minimum 100mm lap on all flashing.
Approved sealant in all flashing laps.
Turn approved underlayment 75mm vertically minimum.

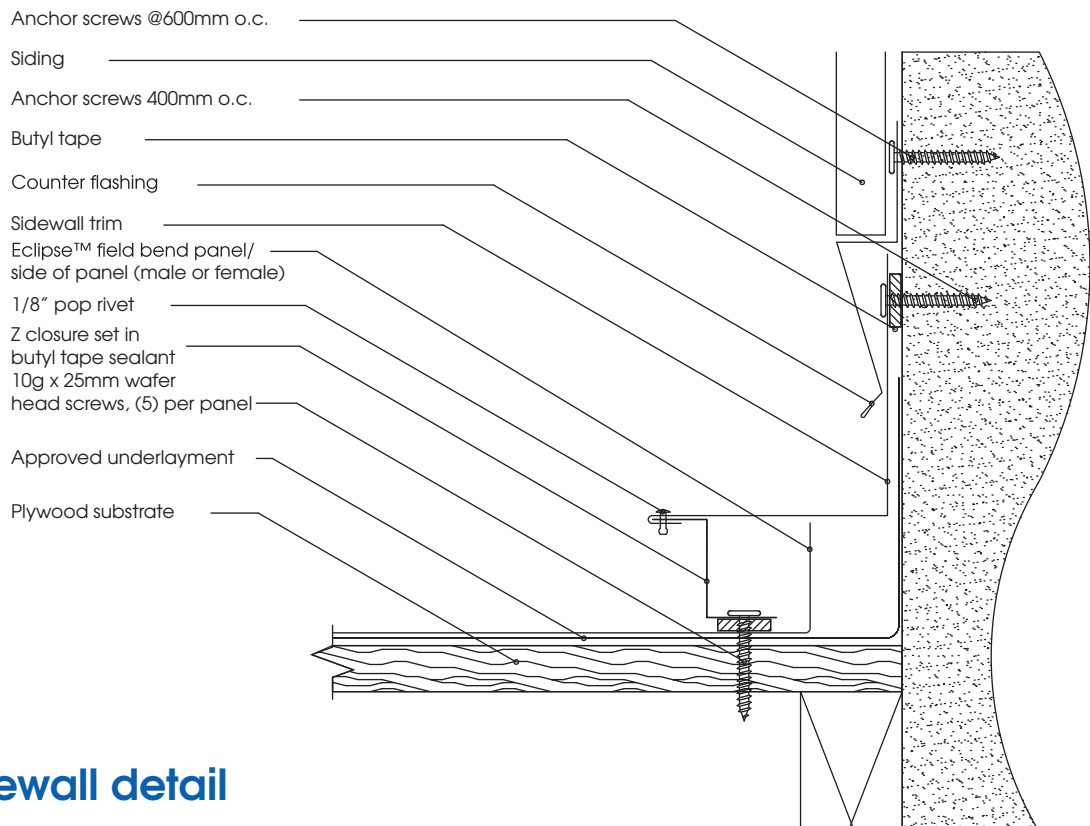

SW2 - Sidewall detail

Note: Minimum 100mm lap on all flashing.
Approved sealant in all flashing laps.
Turn approved underlayment 75mm vertically minimum.

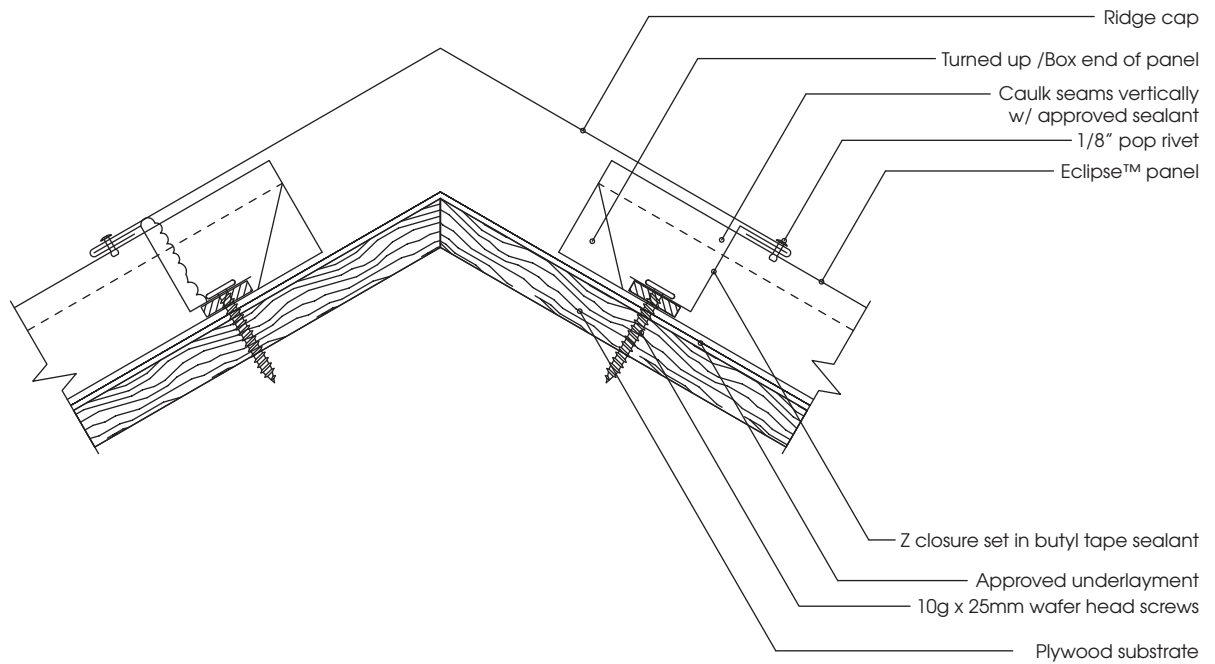

HR1 – Standard hip/ridge detail

Note: Minimum 100mm lap on all flashing.
Approved sealant in all flashing laps.

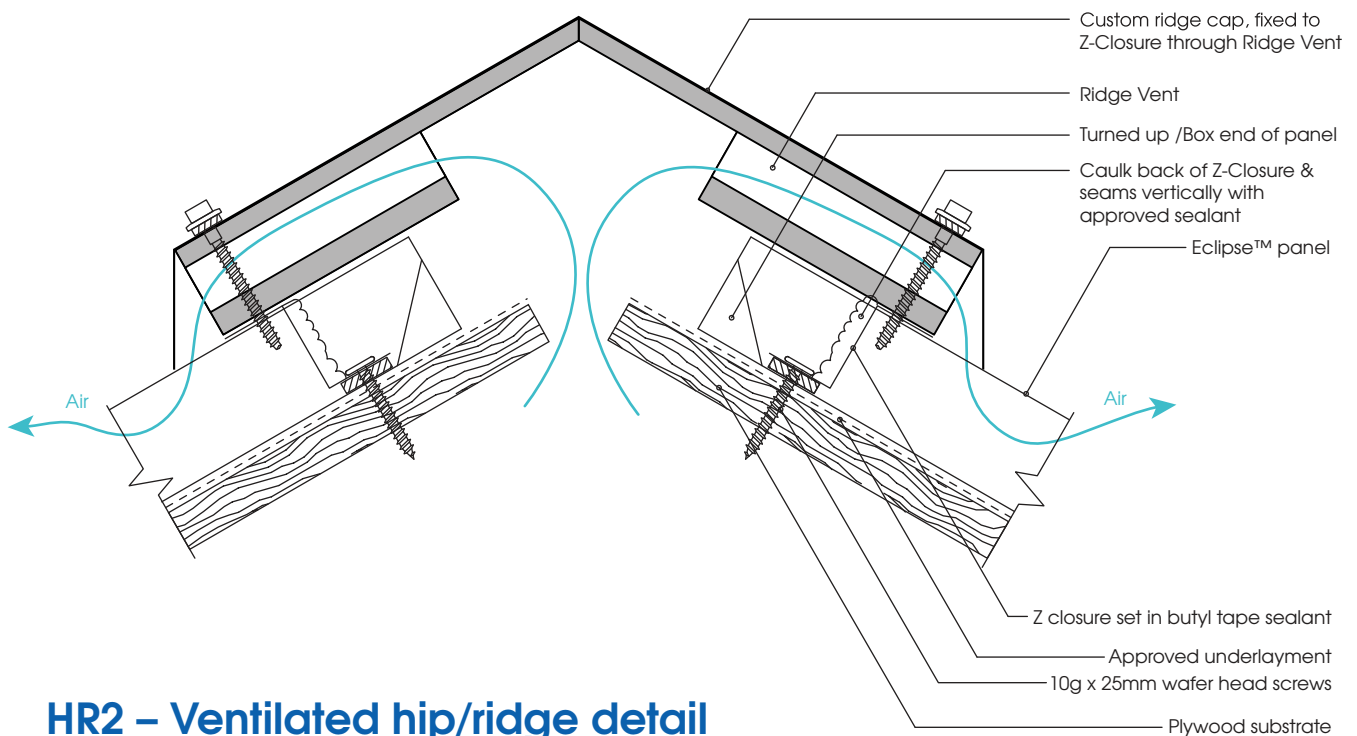

HR2 – Ventilated hip/ridge detail

Note: Minimum 100mm lap on all flashing.
Approved sealant in all flashing laps.

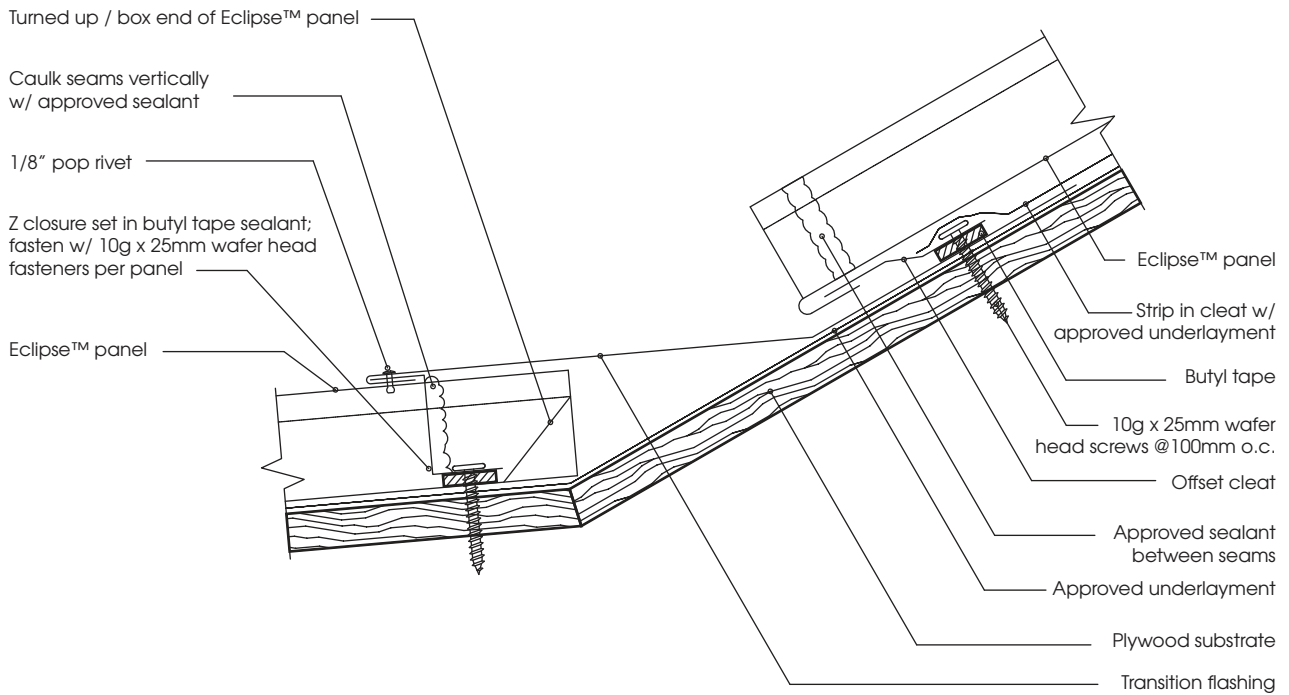

T2 - Roof transition detail

Note: Minimum 100mm lap on all flashing.
Approved sealant in all flashing laps.

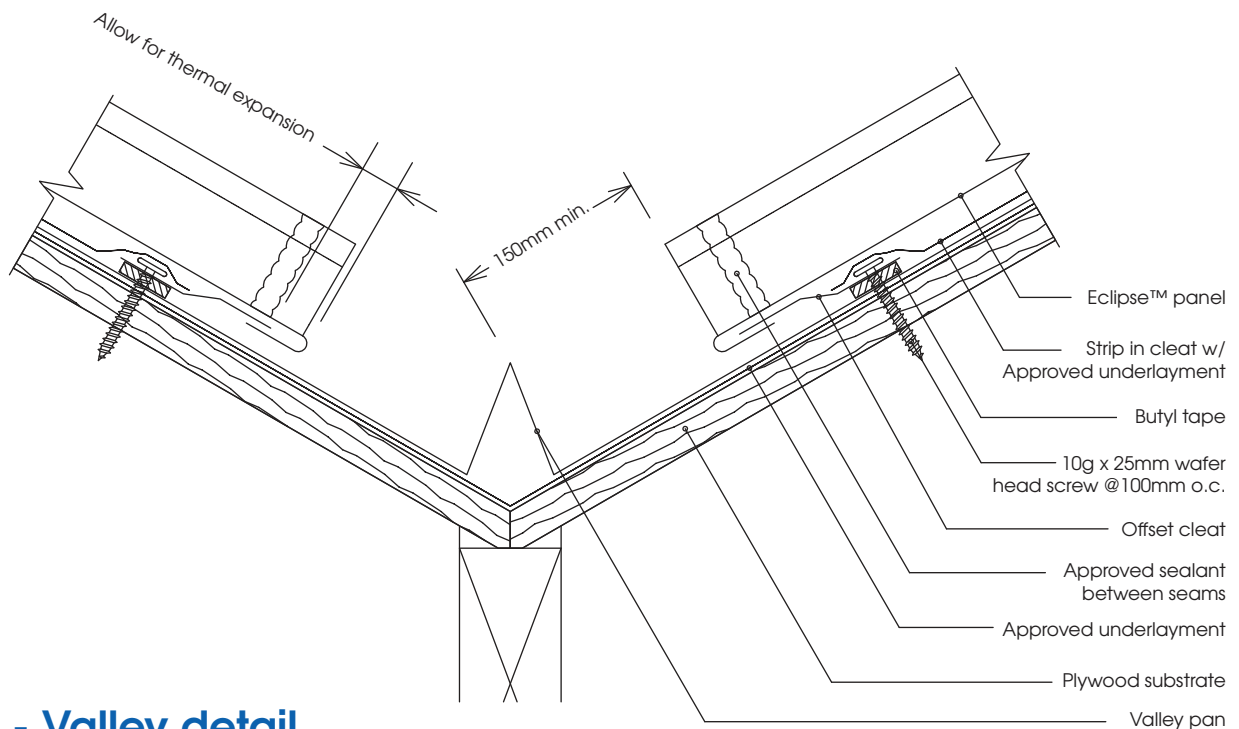

V1 - Valley detail

Note: Laps in valley are 300mm minimum.
Approved sealant in all laps in valley.
Two rows of sealant between valley laps,
100mm up from lap.

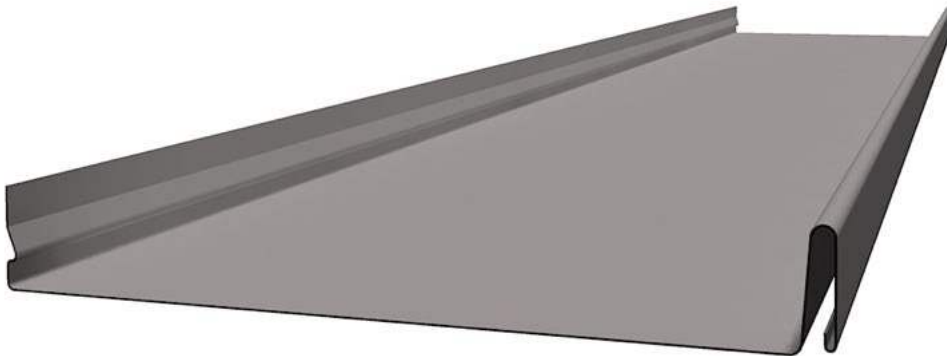

Eclipse™ Wall Cladding Flashing Details on Plywood

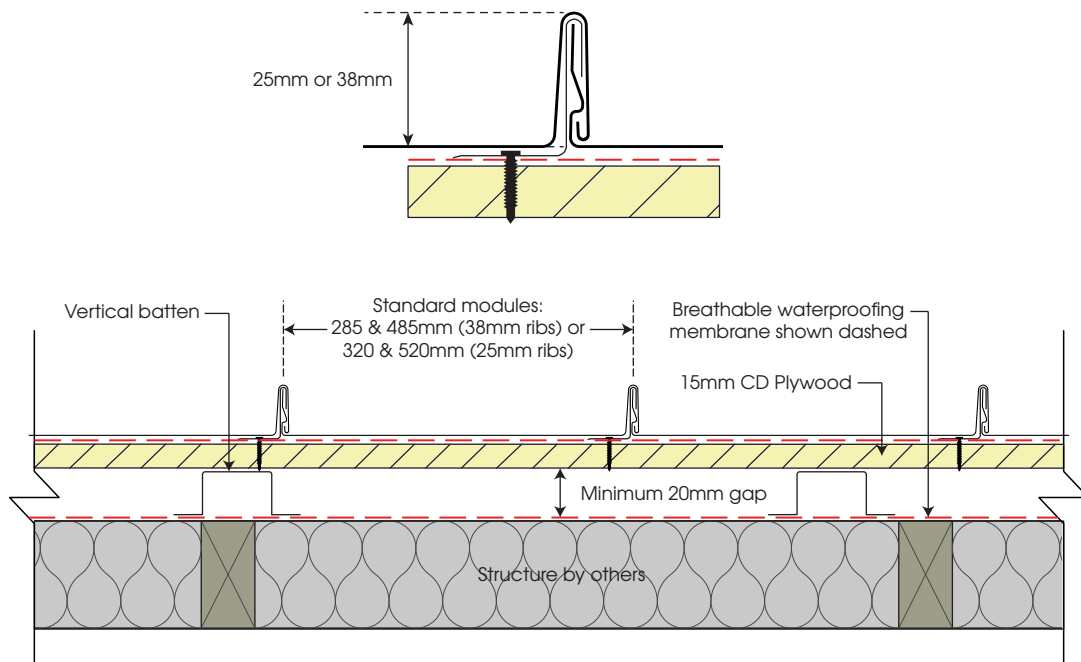

General plan details

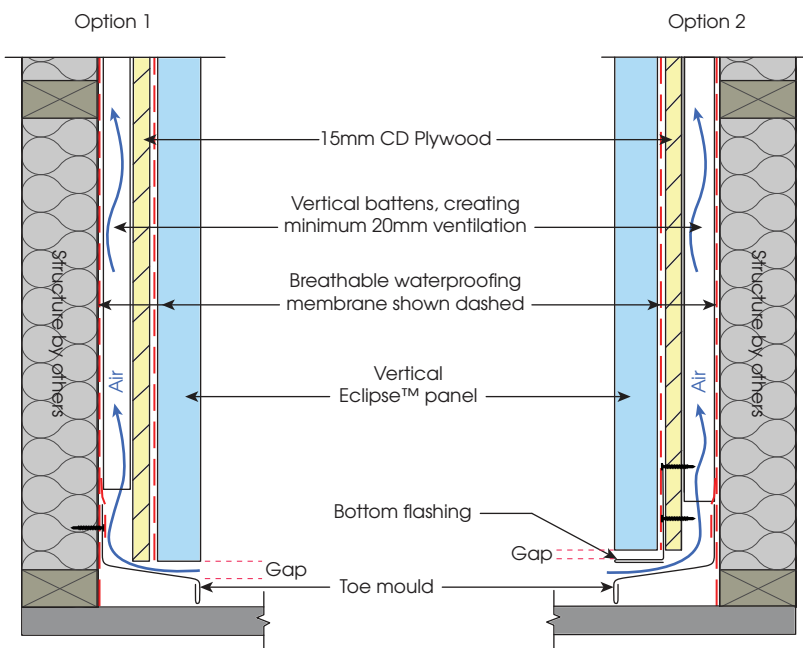

Note:

A minimum gap must always be maintained between the bottom edge of vertical Eclipse™ Snaplock panels and the toe mould or bottom flashing. Panels must never rest directly on the toe mould or flashing.

The required minimum gap is **the greater** of the following:

- 5 mm, or
- Panel length (in metres) x
 - a. 1.2 for steel-based (e.g., Colorbond) panels
 - b. 2.3 for aluminium-based panels

Examples:

A 3m Colorbond panel: $3 \times 1.2 = 3.6$ mm
→ use 5mm gap

A 3m aluminium panel: $3 \times 2.3 = 6.9$ mm
→ use 6.9mm gap

Typical bottom flashing detail - cross section

Note: For BAL areas, gaps might need to be closed off or sealed, to avoid ember ingress. For projects in BAL areas, please consult with No.1 APS team.

Typical parapet detail

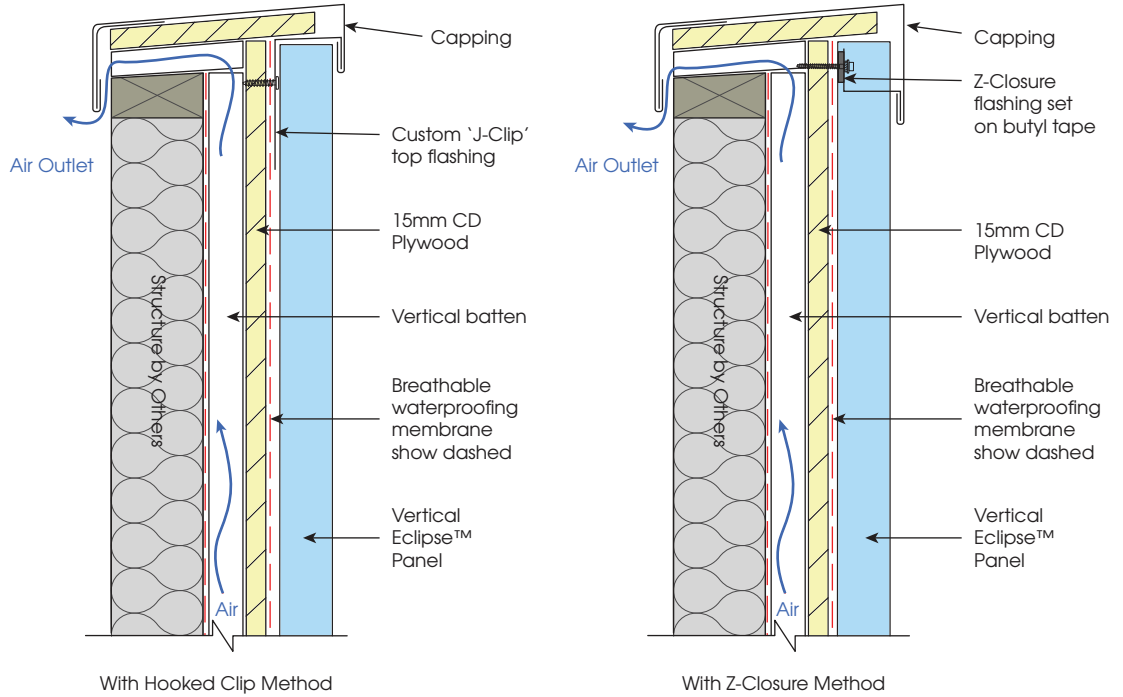

Typical top of wall detail

Note: To avoid vermin ingress, metal mesh can be used on ventilation gaps. For more information, please enquire with No.1 APS team.

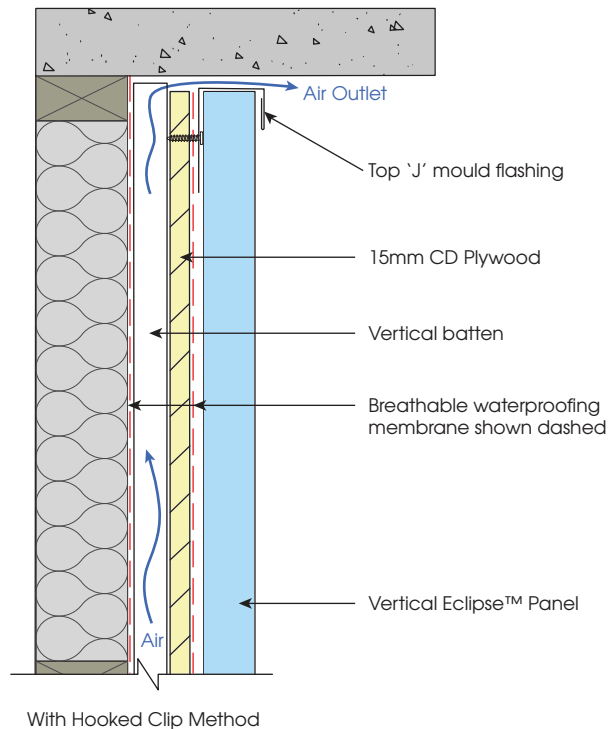

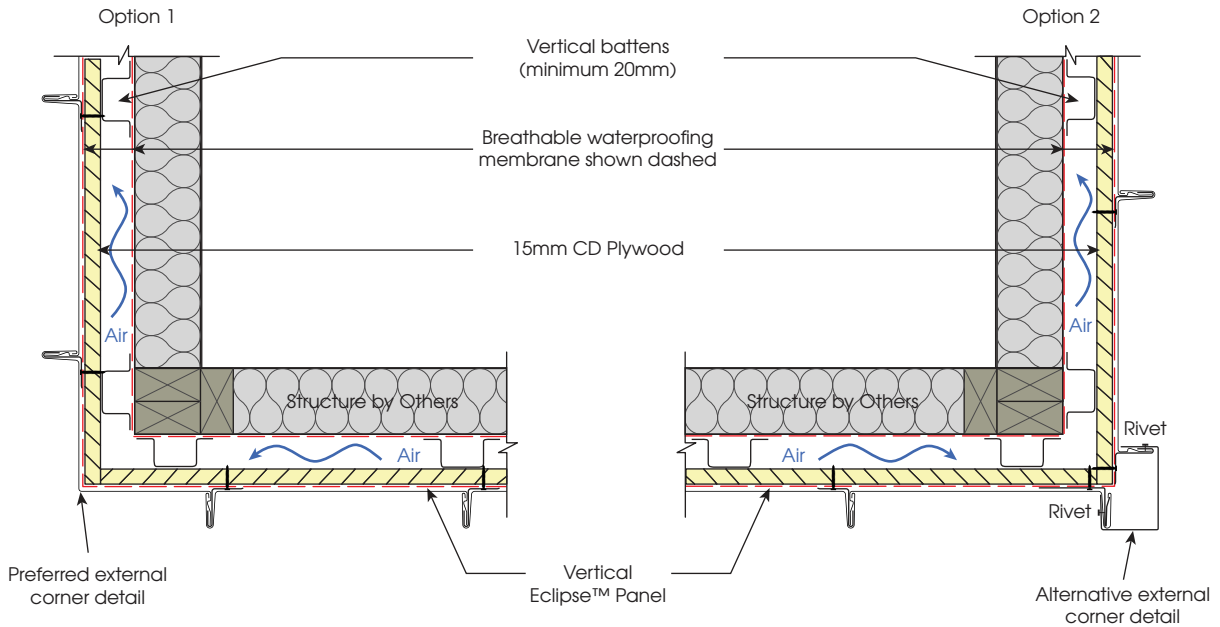

Typical external corner detail

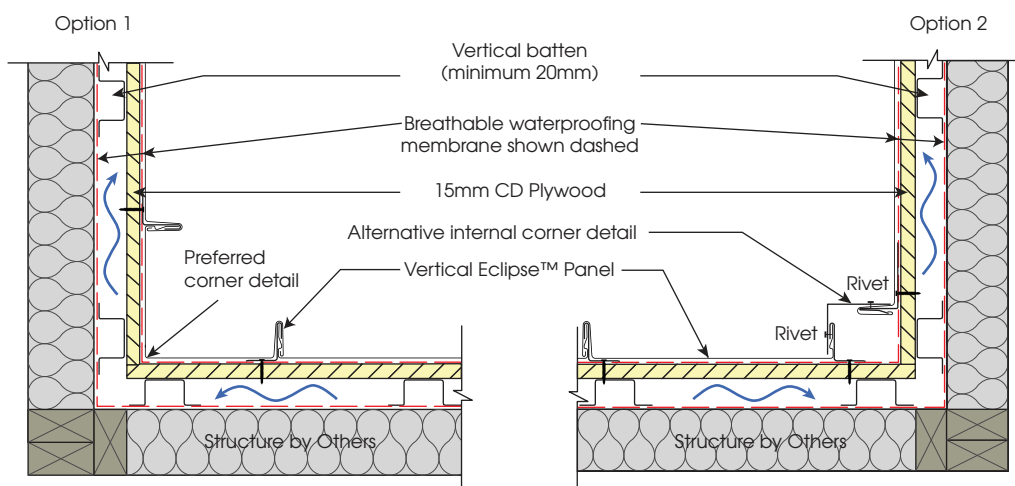

Typical internal corner detail

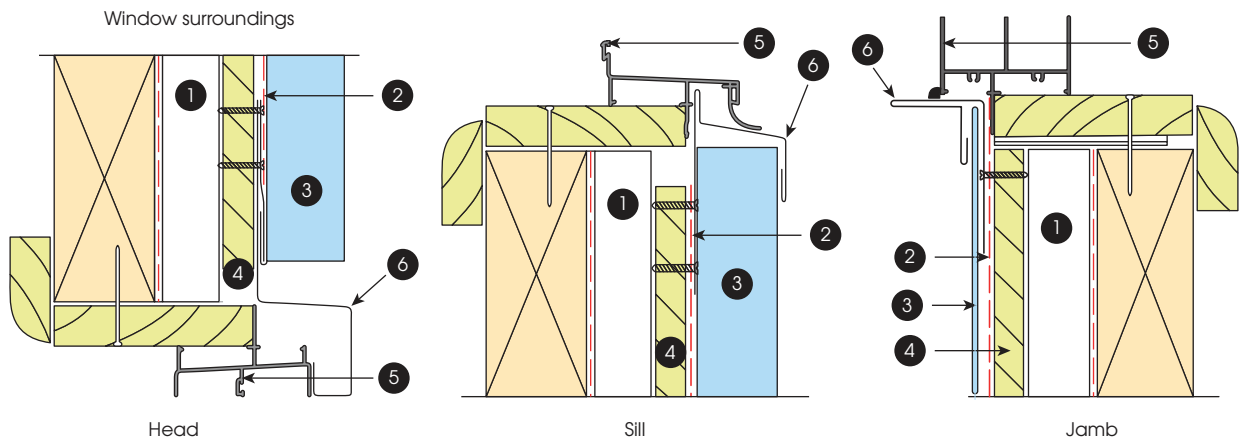

Typical timber reveal window detail

- 1 Vertical Battens min 20mm
- 2 Breathable waterproofing membrane shown dashed
- 3 Vertical Eclipse™ panel
- 4 15mm CD plywood
- 5 Window supplied by others
- 6 Flashing

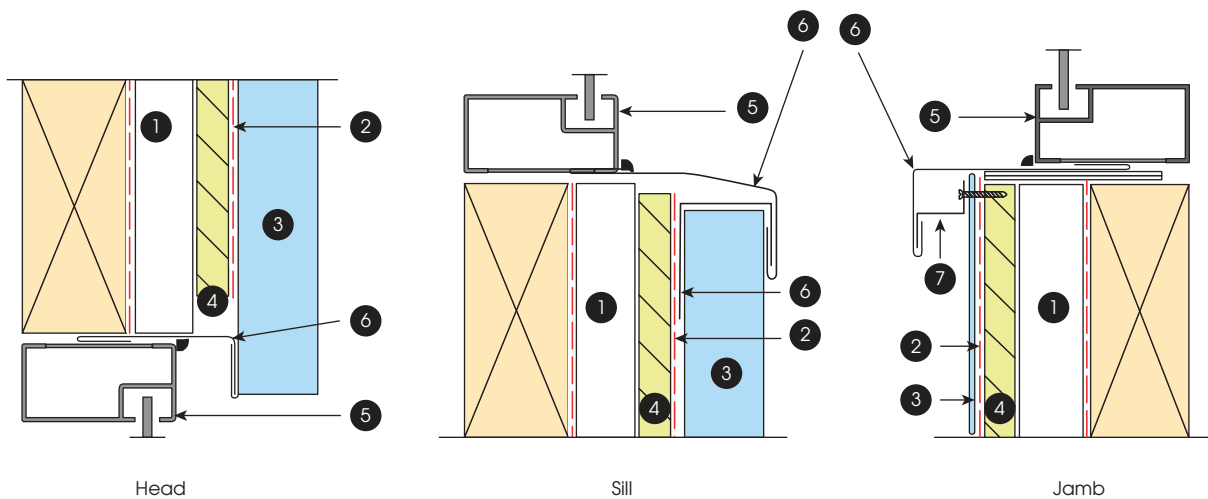

Typical window detail

- 1 Vertical Battens min 20mm
- 2 Breathable waterproofing membrane shown dashed
- 3 Vertical Eclipse™ panel
- 4 15mm CD plywood
- 5 Window supplied by others
- 6 Flashing
- 7 Z-closure flashing installed over sealer/Butyl tape

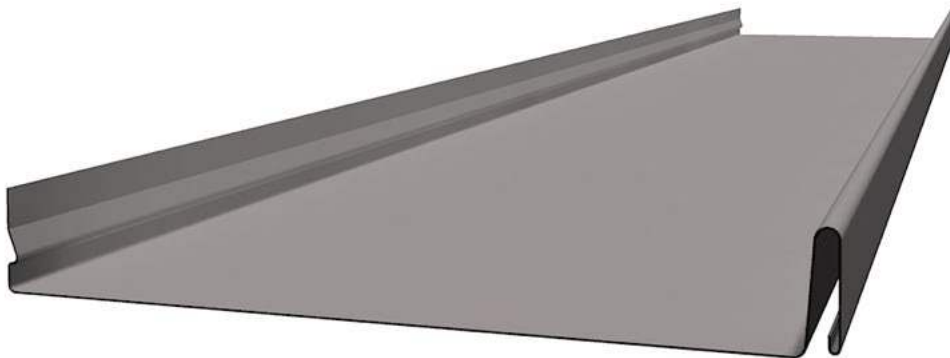

Eclipse™

Roof Cladding Flashing Details on Steel Batten

*Only recommended on module 25x320mm or 38x285mm

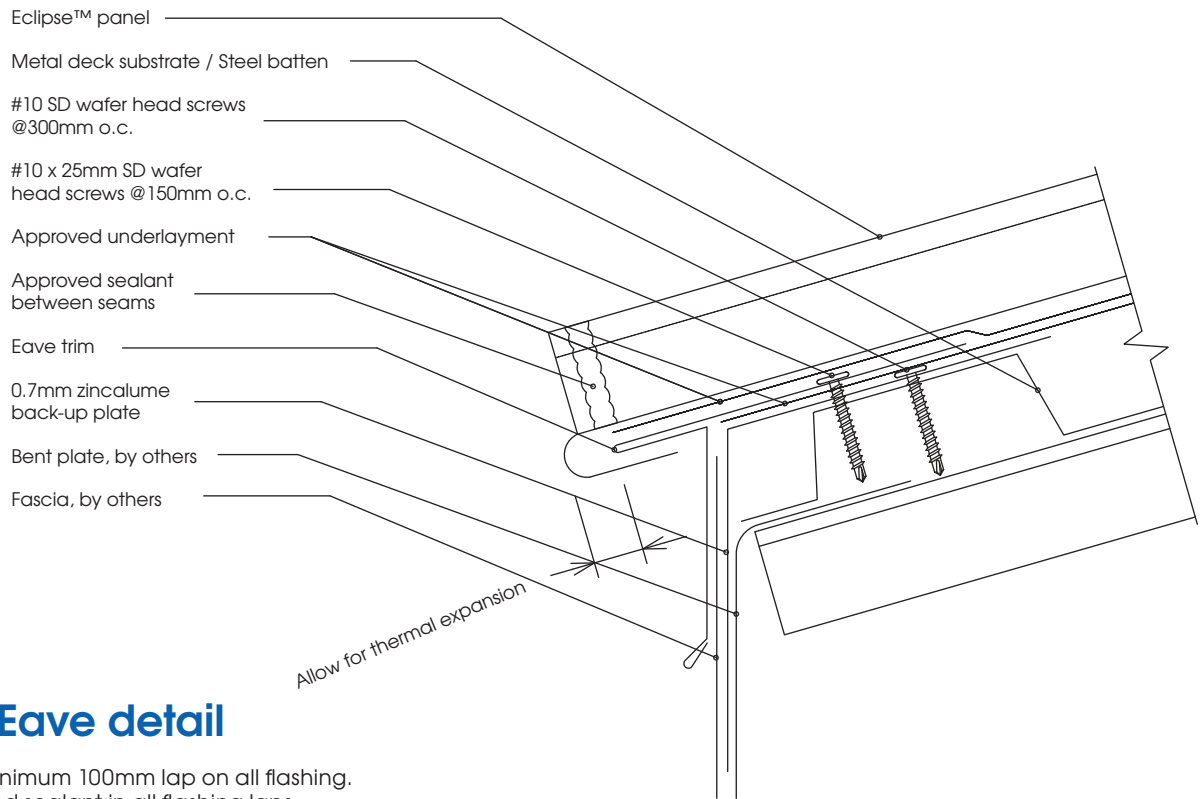

E1 - Eave detail

Note: Minimum 100mm lap on all flashing.
Approved sealant in all flashing laps.

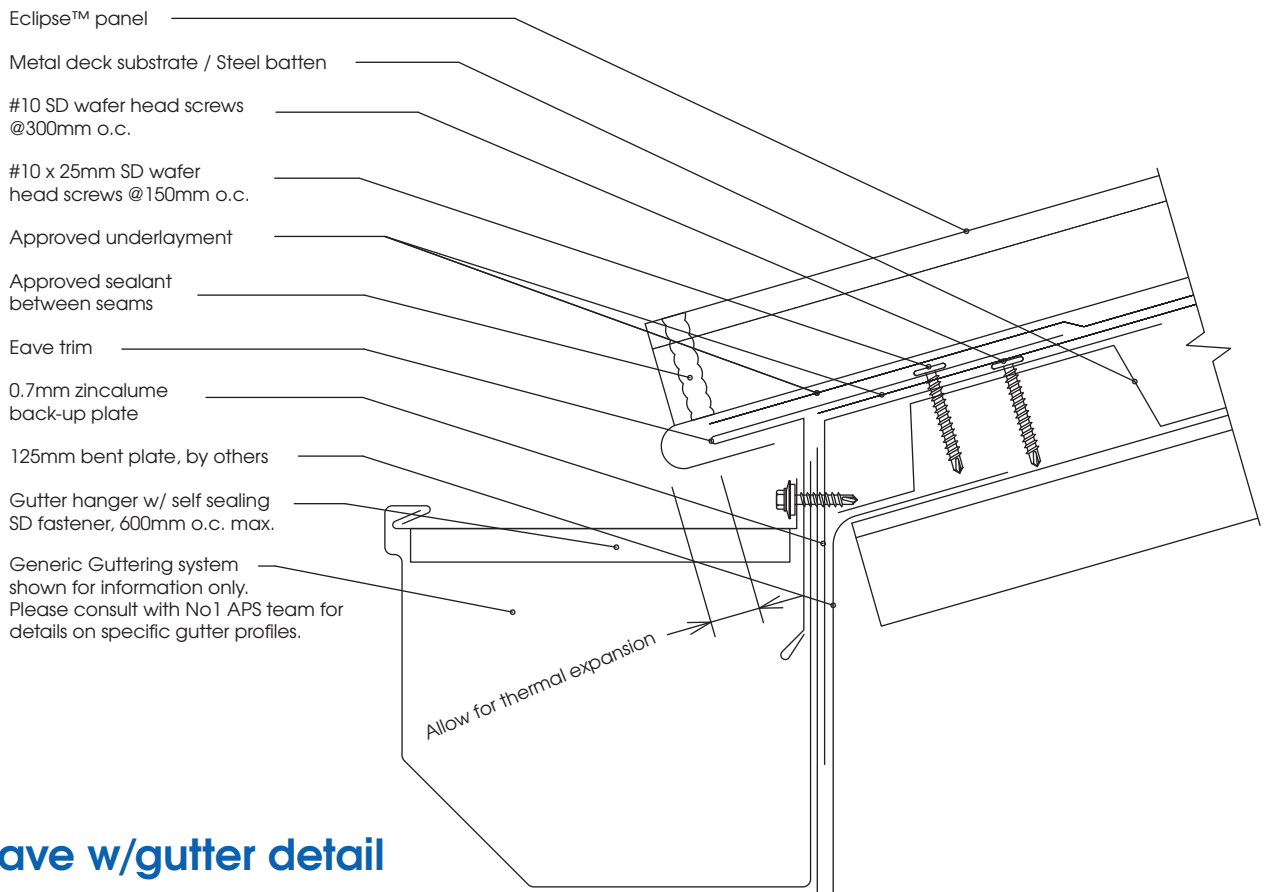

Eave w/gutter detail

Note: Minimum 100mm lap on all flashing.
Approved sealant in all flashing laps.

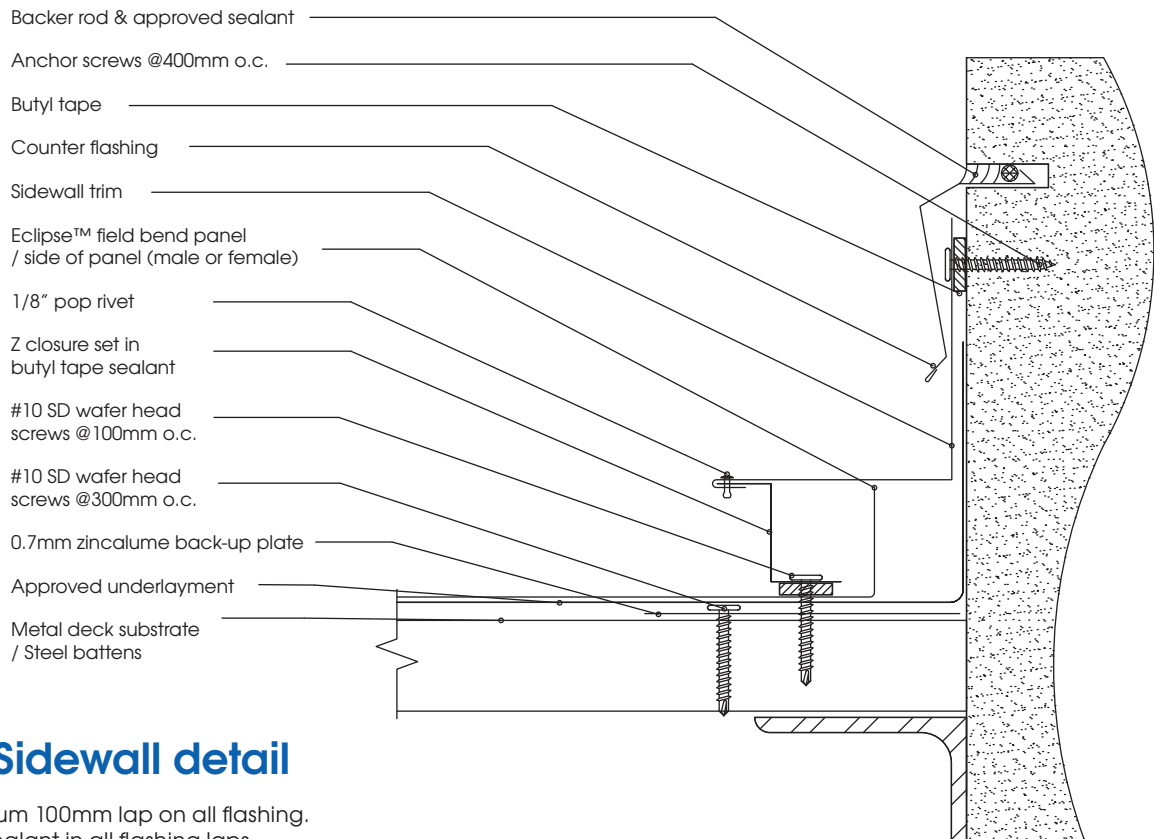

SW1 - Sidewall detail

Note: Minimum 100mm lap on all flashing.
Approved sealant in all flashing laps.
Turn approved underlayment 75mm vertically minimum.

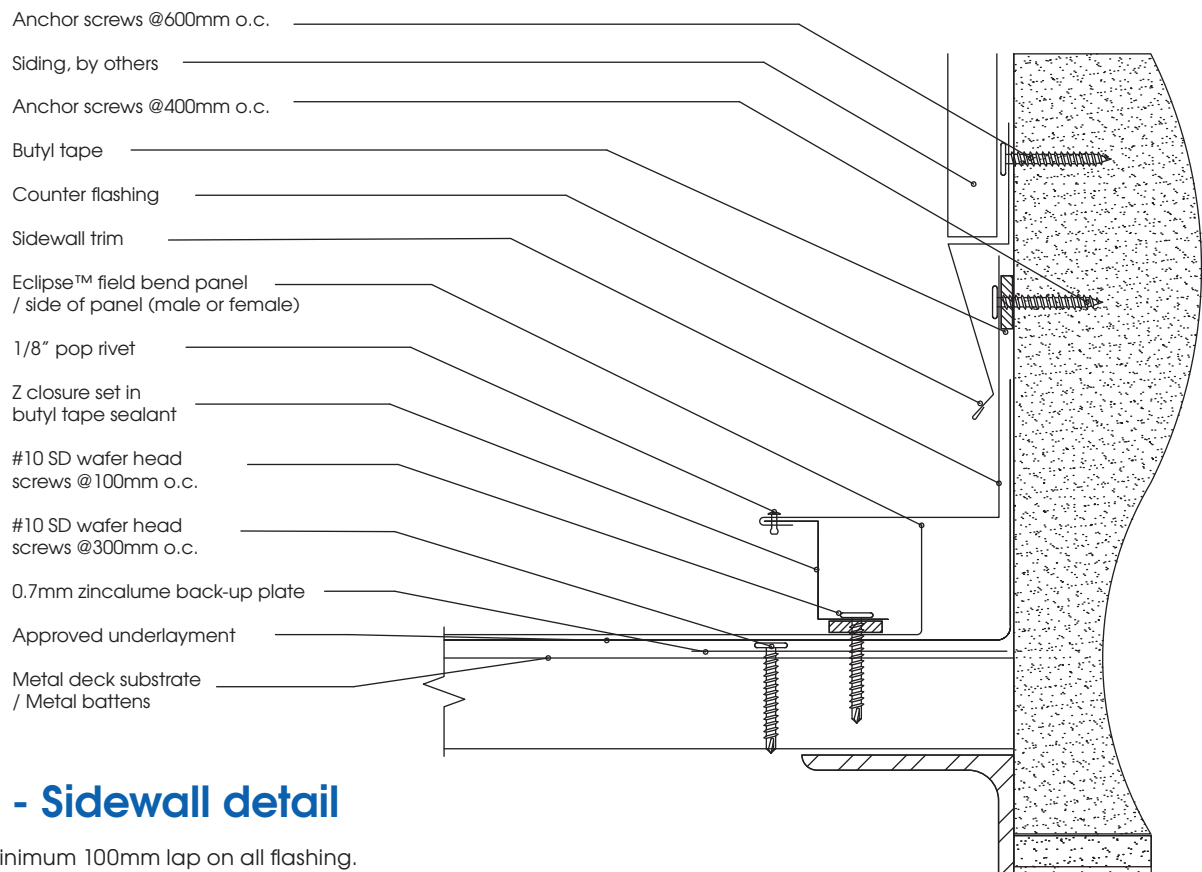

SW2 - Sidewall detail

Note: Minimum 100mm lap on all flashing.
Approved sealant in all flashing laps.
Turn approved underlayment 75mm vertically minimum.

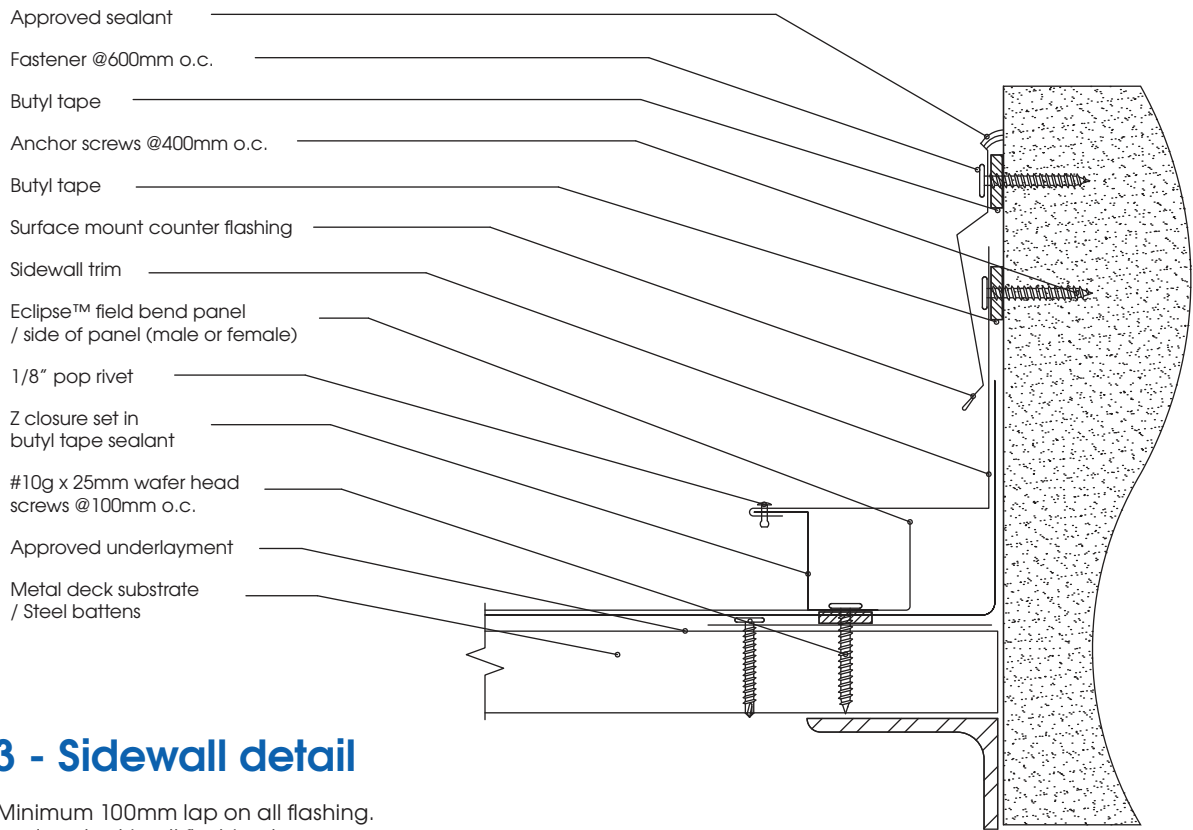

SW3 - Sidewall detail

Note: Minimum 100mm lap on all flashing.
Approved sealant in all flashing laps.
Turn approved underlayment 75mm vertically minimum.

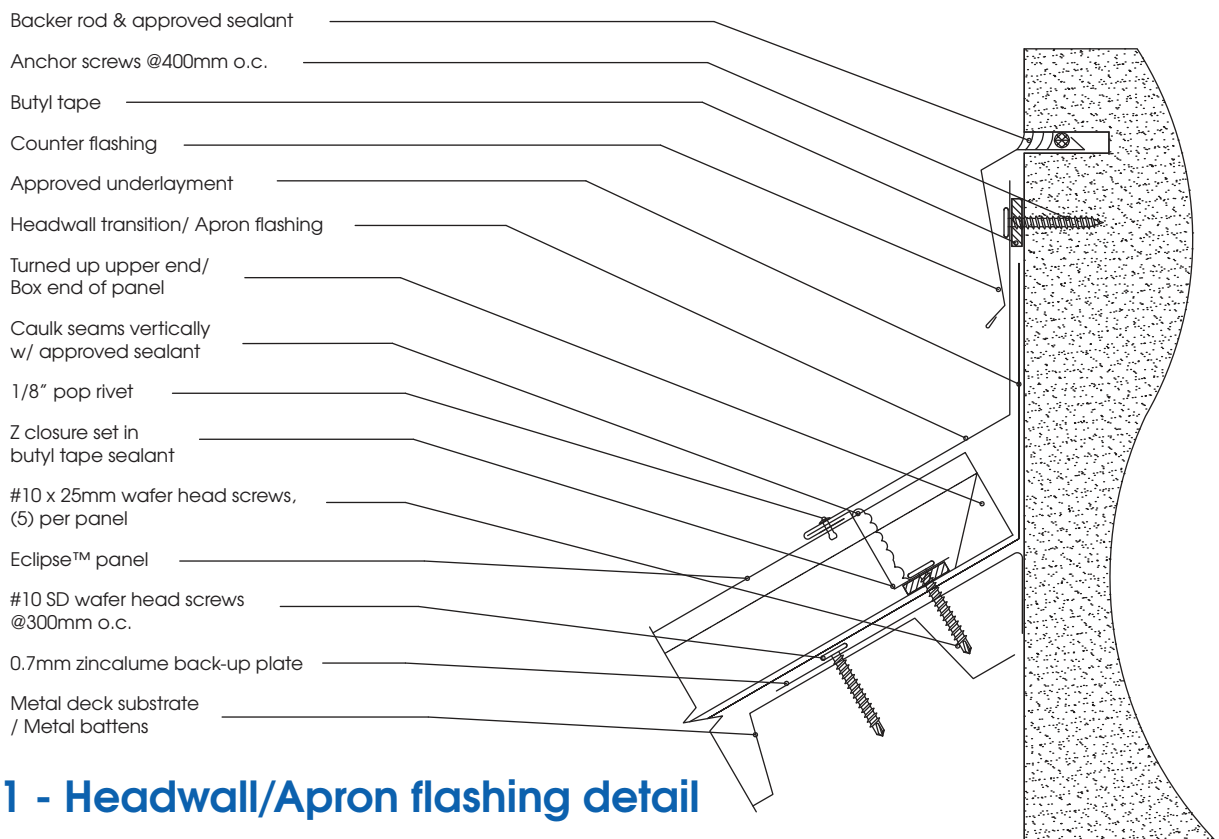

HW1 - Headwall/Apron flashing detail

Note: Minimum 100mm lap on all flashing.
Approved sealant in all flashing laps.
Turn approved underlayment 75mm vertically minimum.

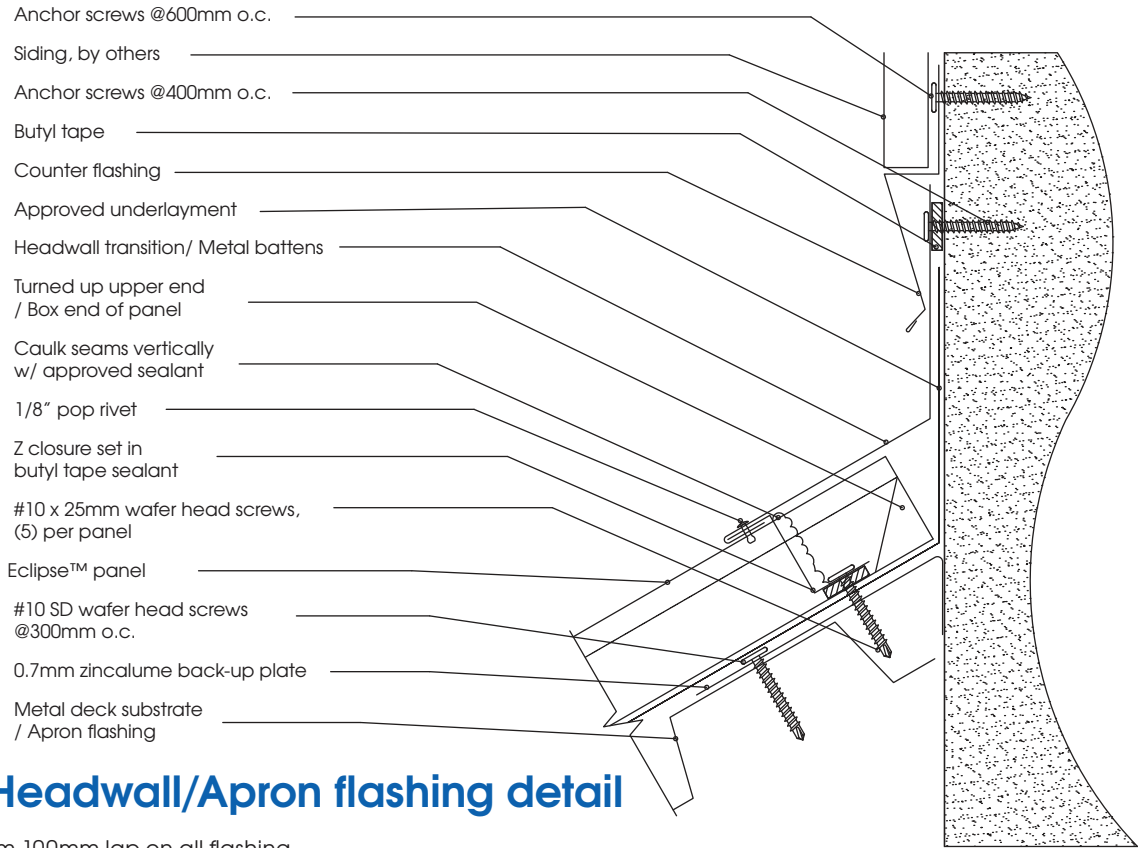

HW2 - Headwall/Apron flashing detail

Note: Minimum 100mm lap on all flashing.
Approved sealant in all flashing laps.
Turn approved underlayment 75mm vertically minimum.

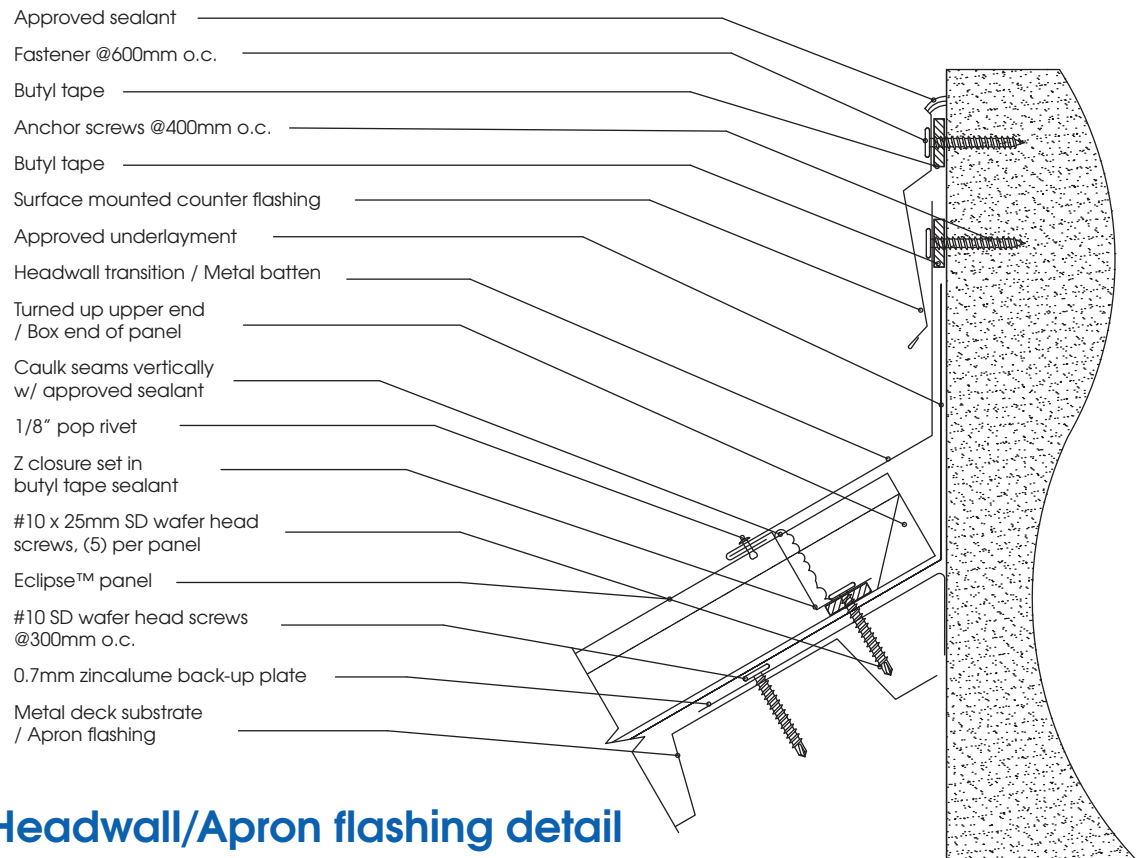

HW3 - Headwall/Apron flashing detail

Note: Minimum 100mm lap on all flashing.
Approved sealant in all flashing laps.
Turn approved underlayment 75mm vertically minimum.

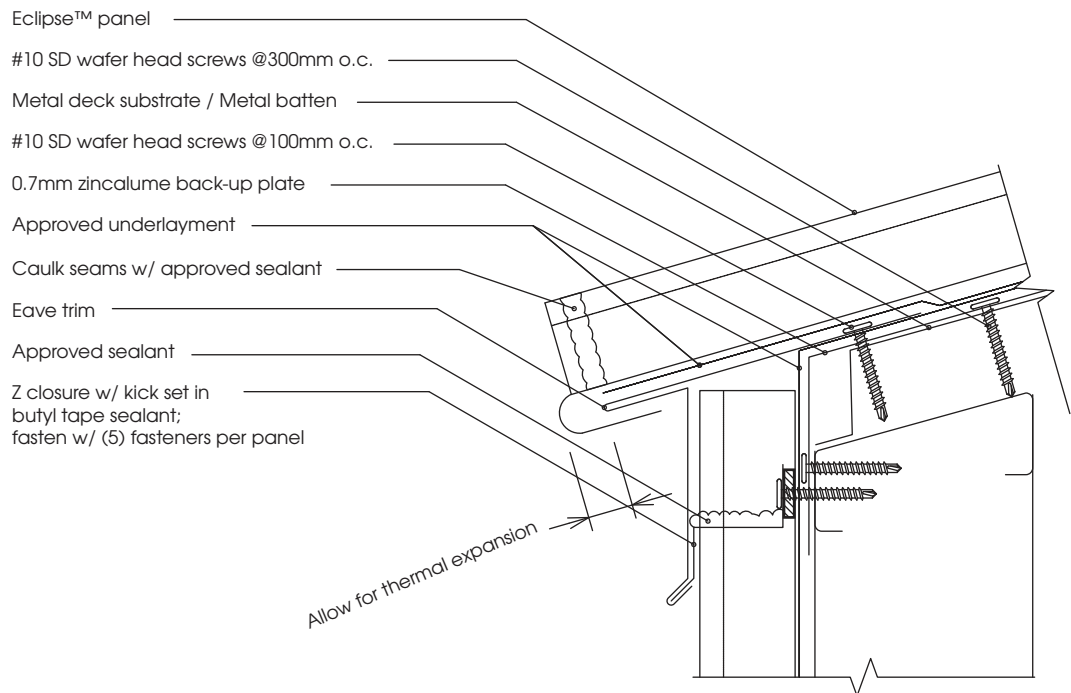

T1 - Roof /Fascia transition detail

Note: Minimum 100mm lap on all flashing.
Approved sealant in all flashing laps.

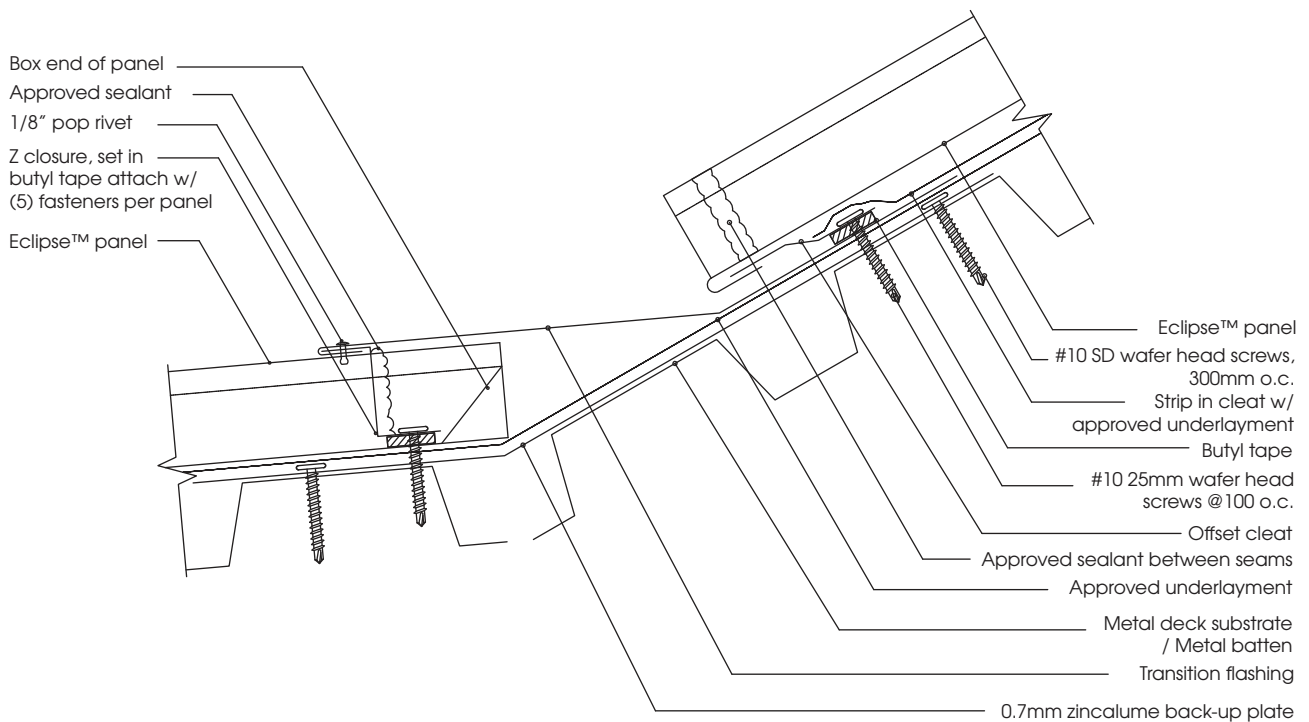

T2 - Roof transition detail

Note: Minimum 100mm lap on all flashing.
Approved sealant in all flashing laps.

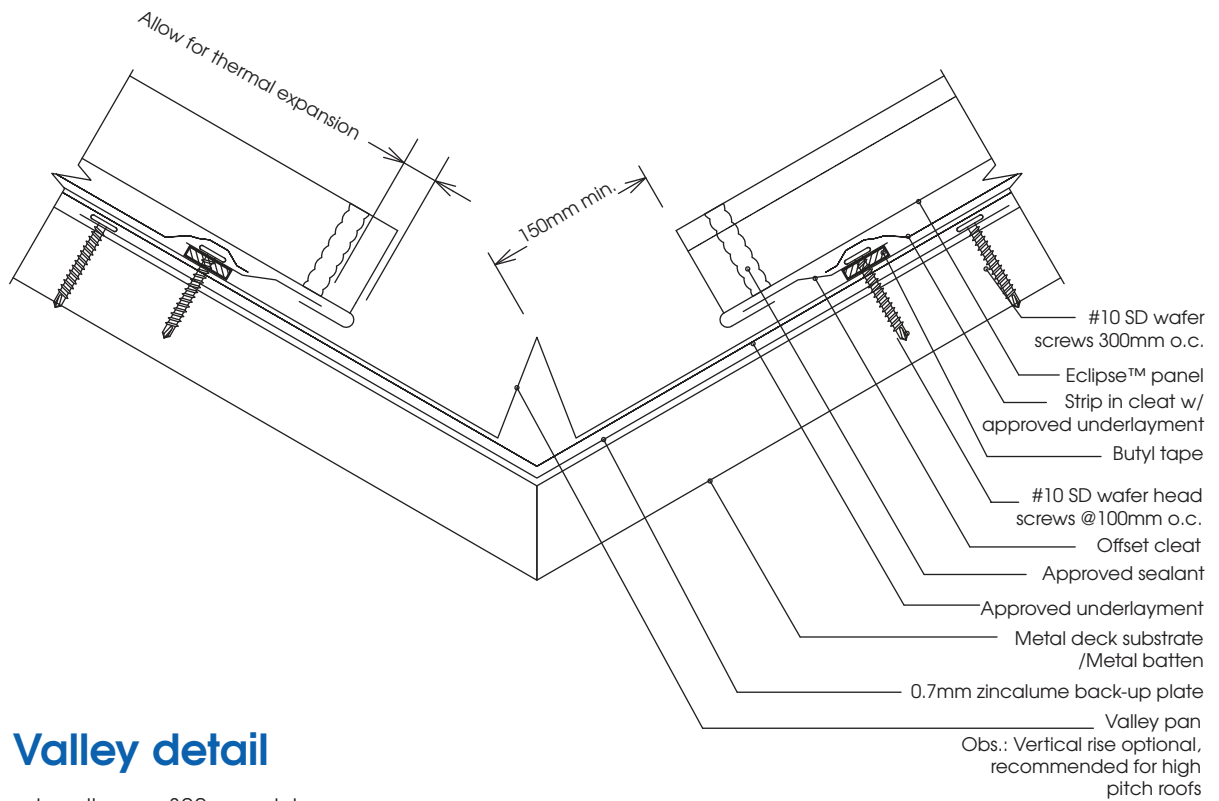

V1 - Valley detail

Note: Laps in valley are 300mm minimum
Approved sealant in all laps in valley
Two rows of sealant between valley laps, 100mm up from lap

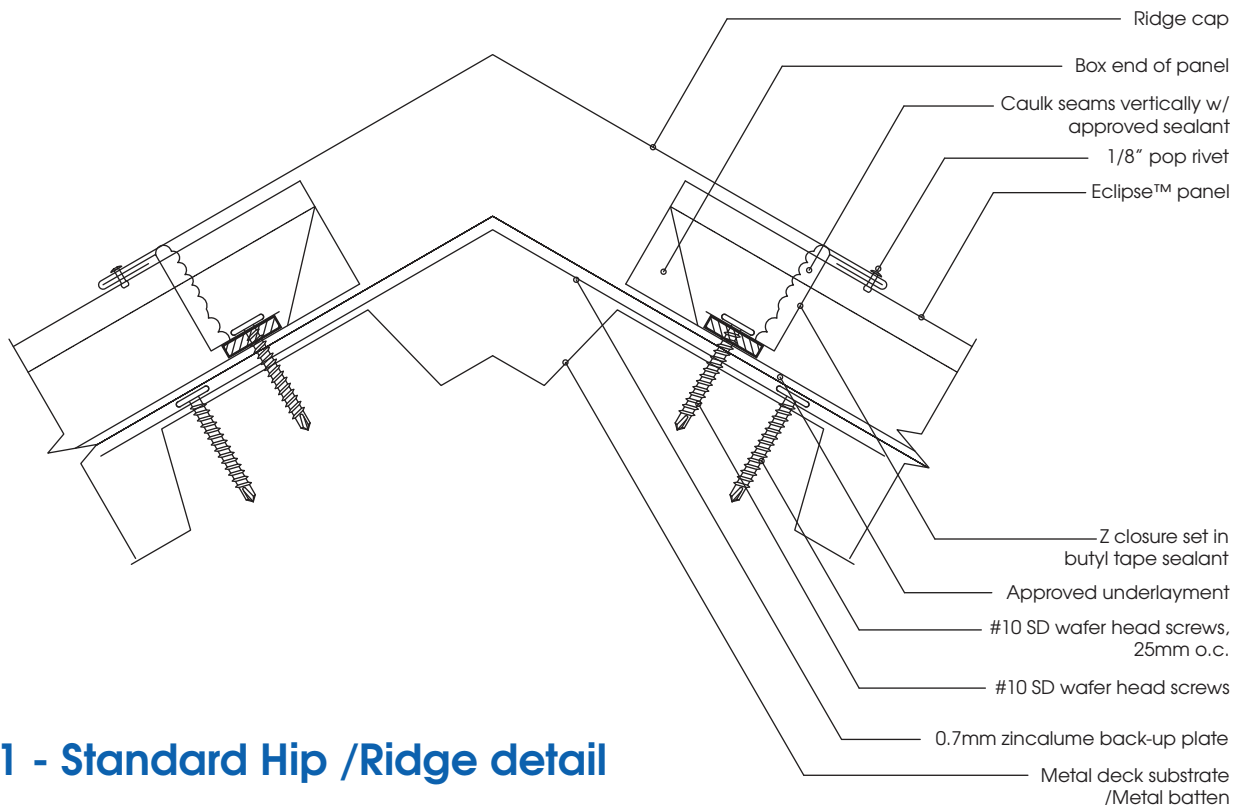

HR1 - Standard Hip /Ridge detail

Note: Minimum 100mm lap on all flashing.
Approved sealant in all flashing laps. For ventilated ridge details, please contact No1 APS Team.

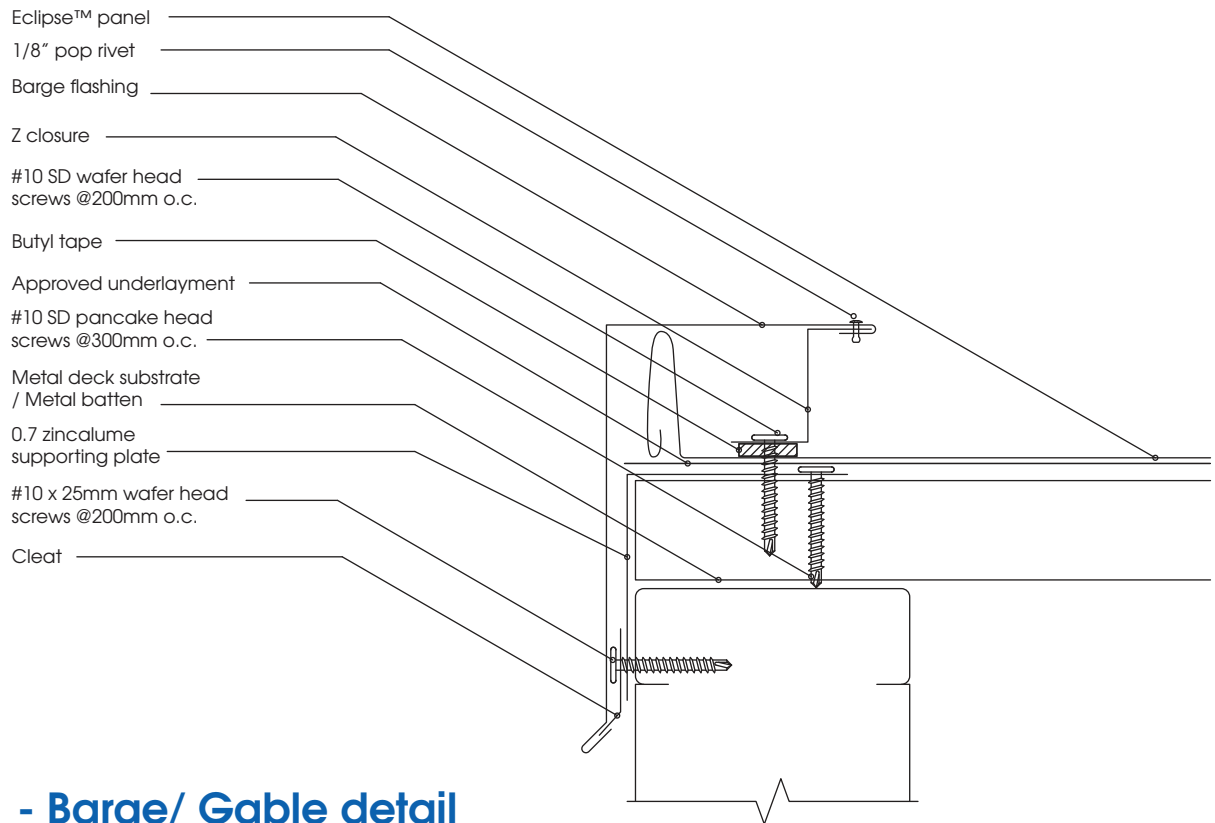

BG1 - Barge/ Gable detail

Note: Minimum 100mm lap on all gable trim
Approved sealant in all laps of gable trim

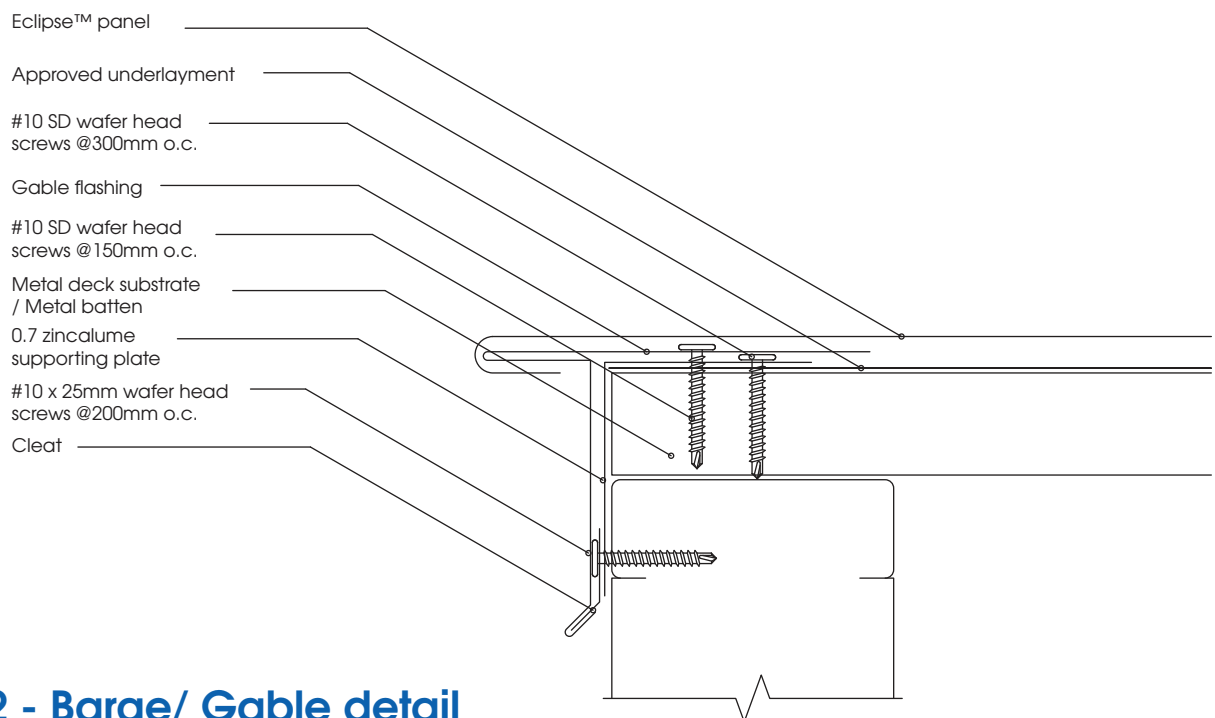

BG2 - Barge/ Gable detail

Note: Minimum 100mm lap on all flashing.
Approved sealant in all flashing laps.

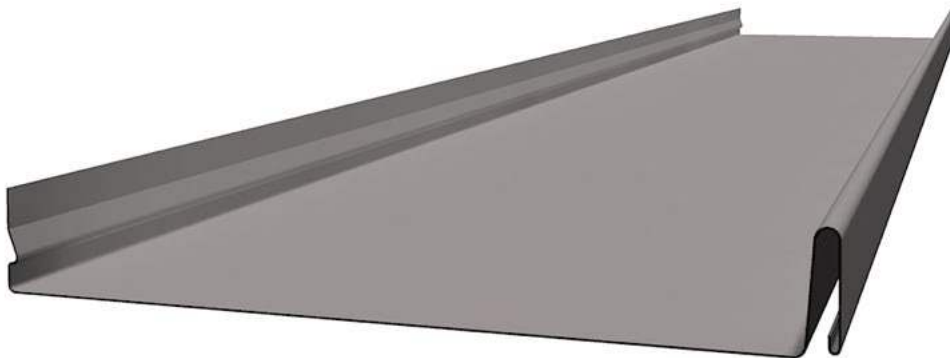

Eclipse™

Wall Cladding Flashing Details on Steel Batten

Eclipse™ Common Wall Types - Installation on Battens

Important: It is recommended that all Eclipse™ installations allow for appropriate condensation management control. Below are the most common wall types, all including options of ventilated cavities. For any custom wall types application of Eclipse™, please consult with our No1 APS Team.

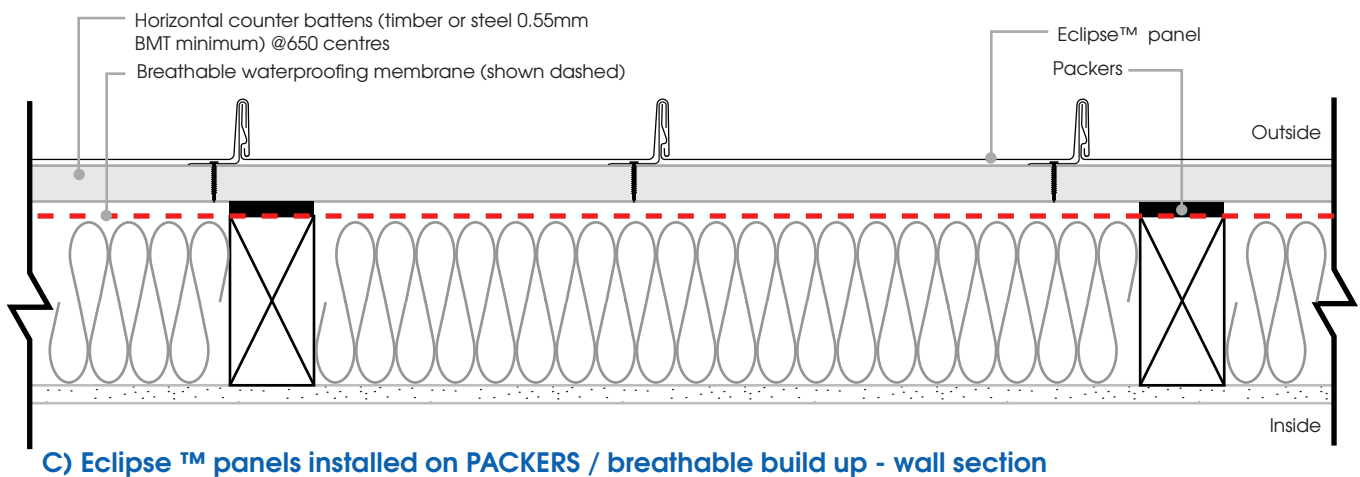
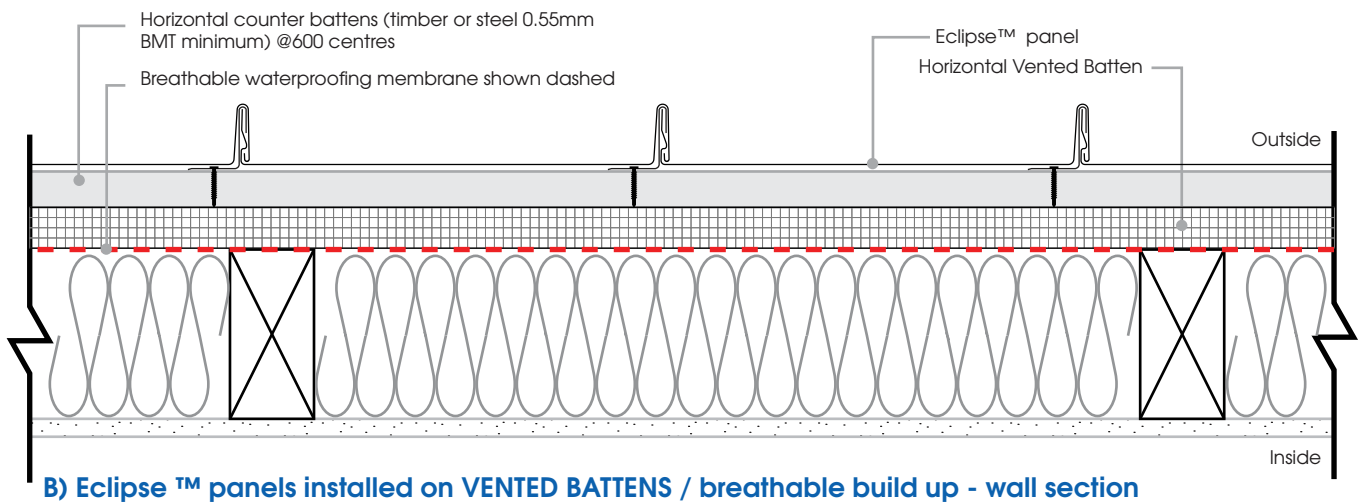
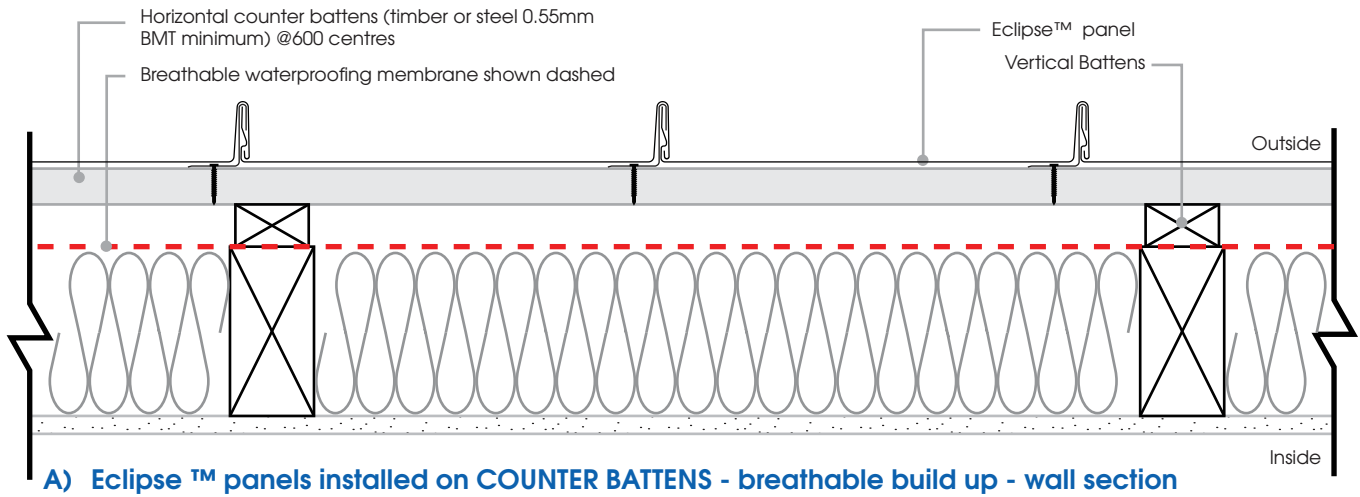

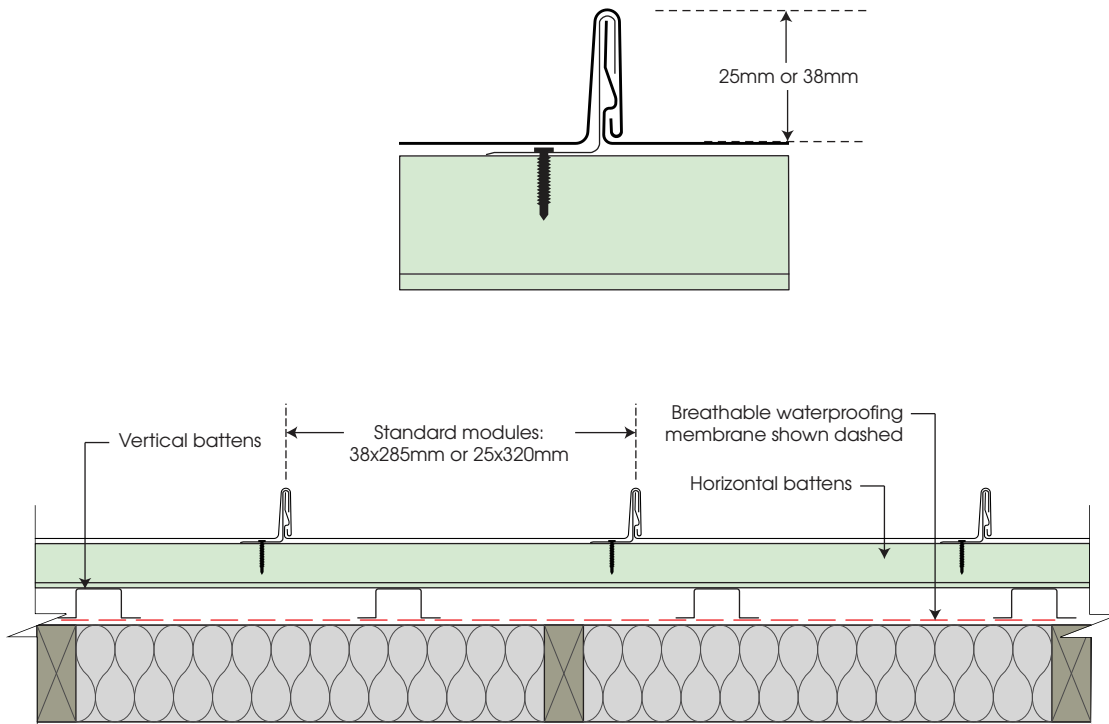

General plan details

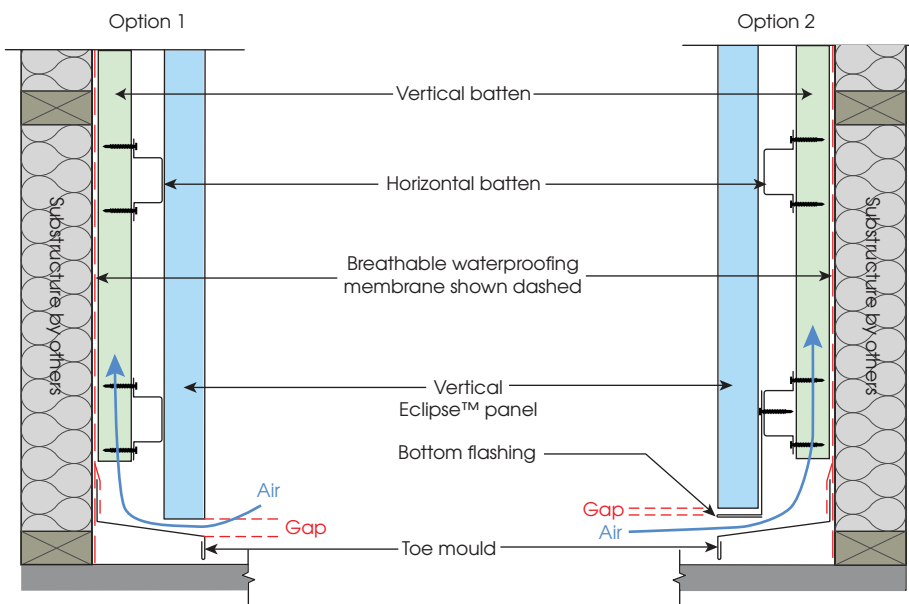

Note:

A minimum gap must always be maintained between the bottom edge of vertical Eclipse™ Snaplock panels and the toe mould or bottom flashing. Panels must never rest directly on the toe mould or flashing.

The required minimum gap is the **greater** of the following:

- 5 mm, or
- Panel length (in metres) ×
 - a. 1.2 for steel-based (e.g., Colorbond) panels
 - b. 2.3 for aluminium-based panels

Examples:

A 3 m Colorbond panel: $3 \times 1.2 = 3.6$ mm → use 5mm gap

A 3 m aluminium panel: $3 \times 2.3 = 6.9$ mm → use 6.9mm gap

Typical bottom flashing detail - cross section

Typical parapet detail

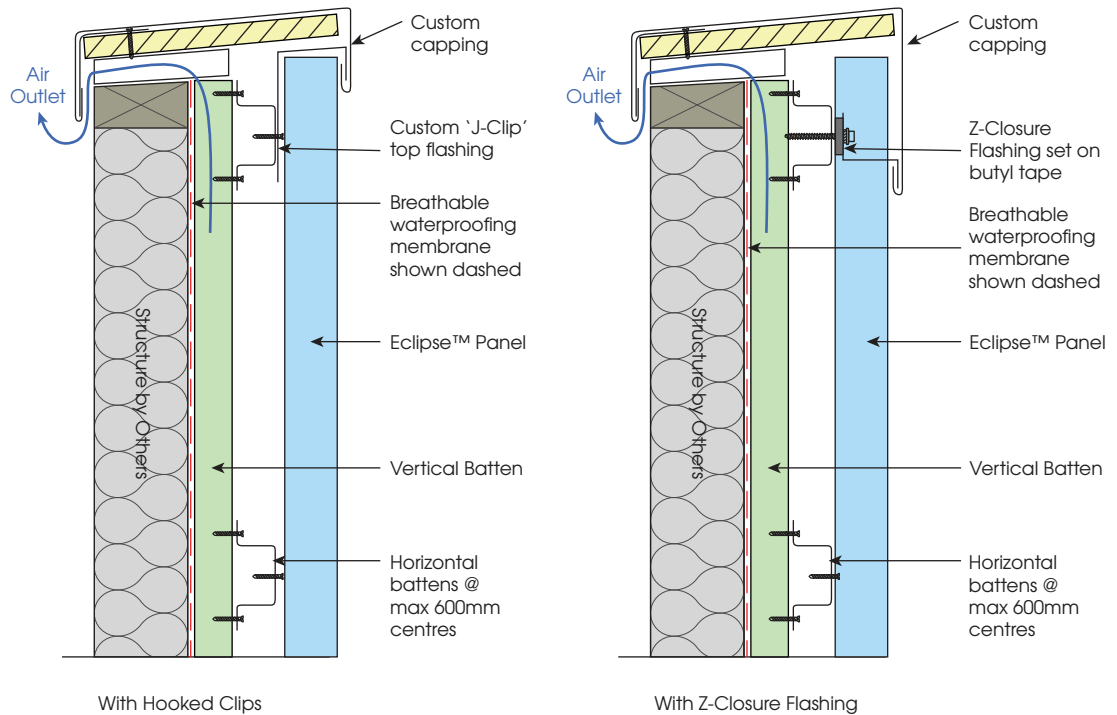

Typical top of wall detail

Note: To avoid vermin ingress, metal mesh can be used on ventilation gaps. For more information, please enquire with No.1 APS team.

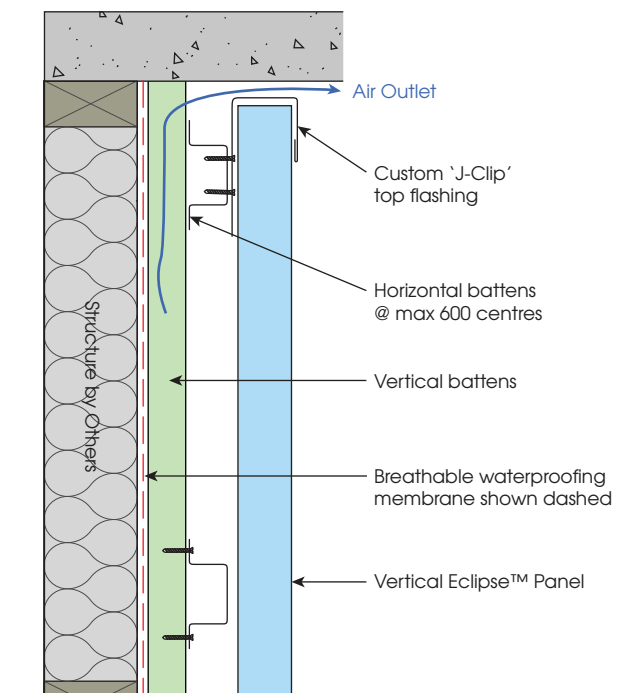

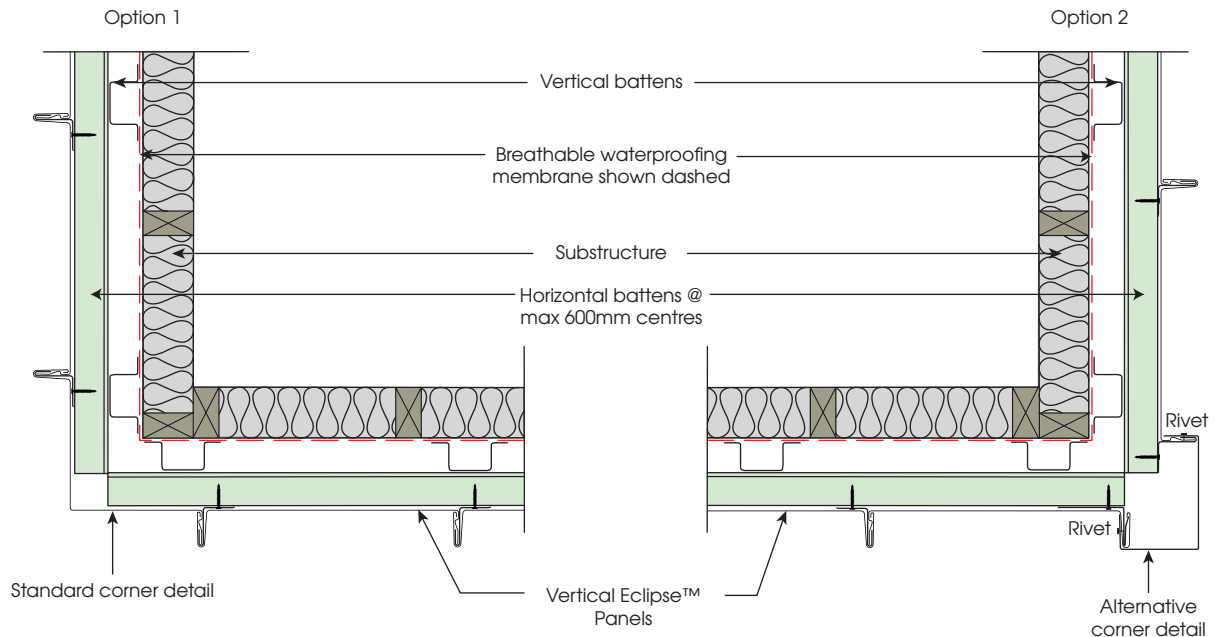

Typical external corner detail

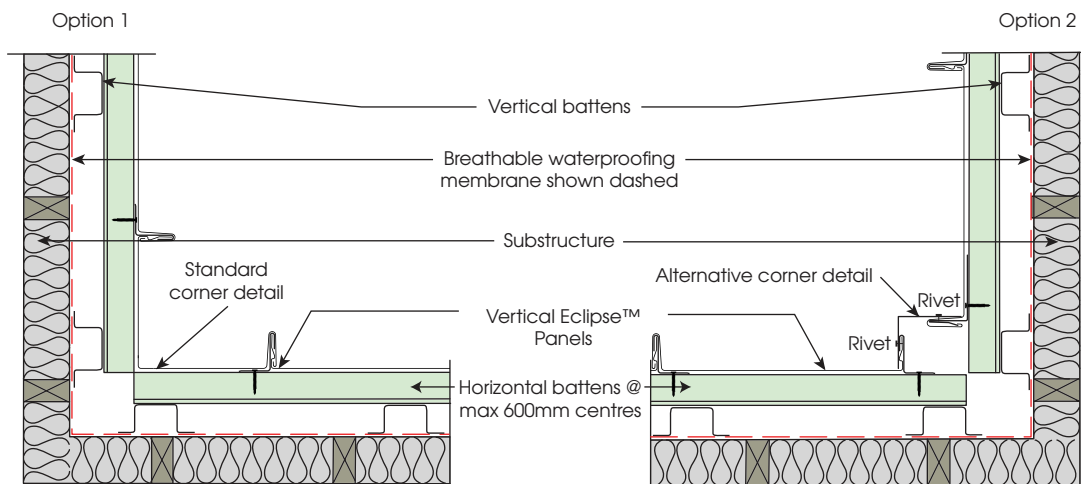

Typical internal corner detail

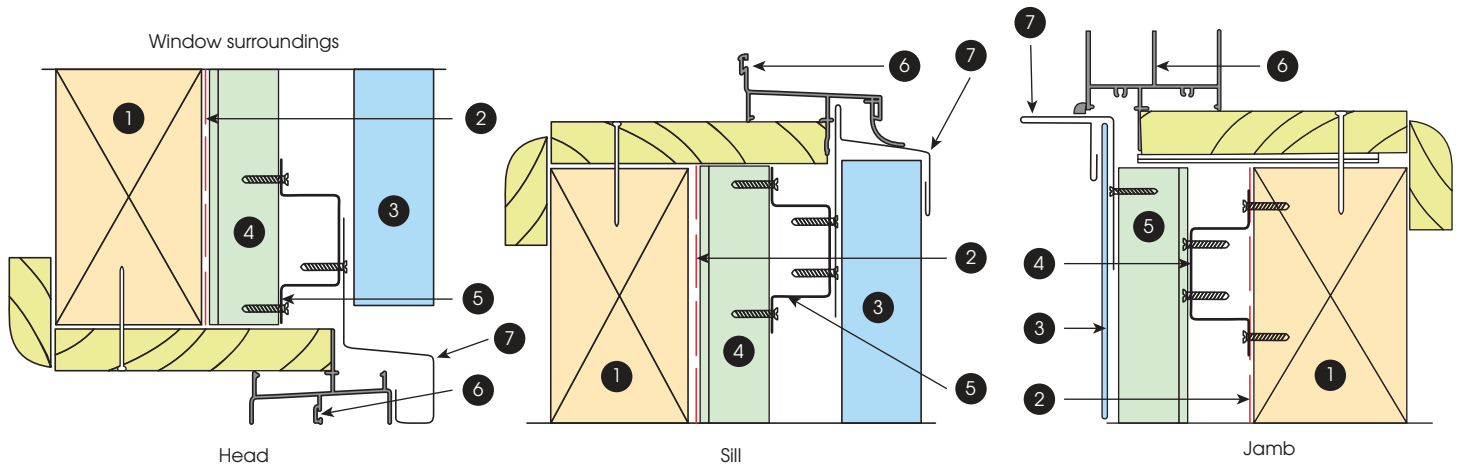

Typical timber reveal window detail

- 1 Substructure supplied by others
- 2 Breathable waterproofing membrane shown dashed
- 3 Vertical Eclipse™ panel
- 4 Vertical Battens
- 5 Horizontal battens @ max 600mm centres
- 6 Window supplied by others
- 7 Flashing

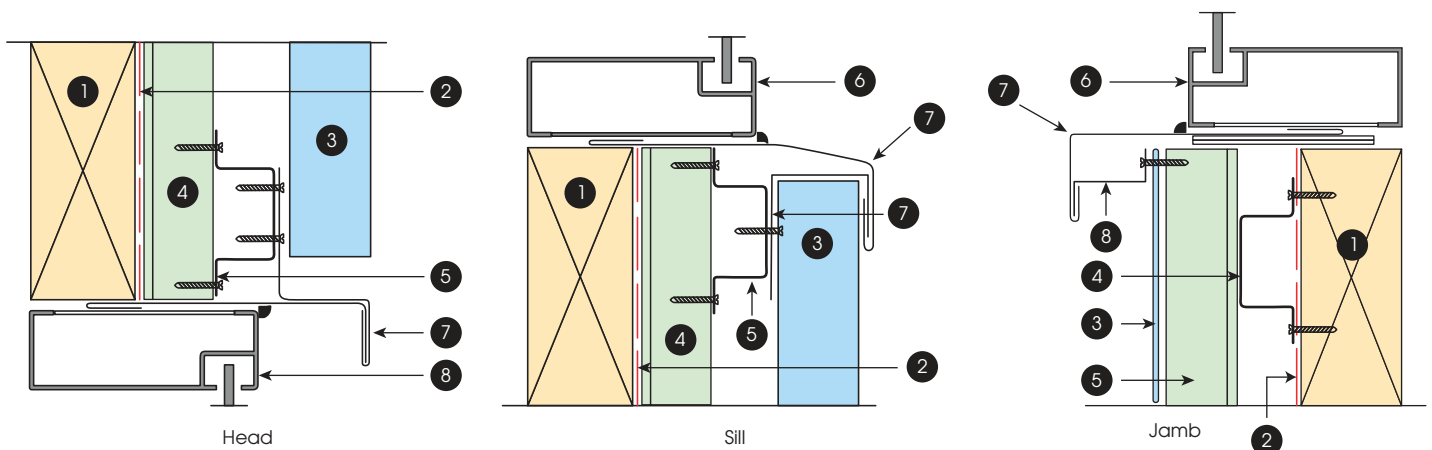

Typical window detail

- 1 Substructure
- 2 Breathable waterproofing membrane shown dashed
- 3 Vertical Eclipse™ panel
- 4 Vertical battens
- 5 Horizontal battens @ max 600mm centres
- 6 Window supplied by others
- 7 Flashing
- 8 Z-closure flashing installed over sealer/Butyl tape

No1 Roofing & Building Supplies



No1 Architectural Panel Systems
Manufactured by No1 Roofing & Building Supplies

1300 742 011
aps@no1roofing.com.au

www.no1aps.com.au

Version Two